



# **JAMAICA MILLENNIUM MOTORING CLUB**

## **MOTOR SPORTS RULES AND REGULATIONS**

### **GENERAL REGULATIONS**

The Jamaica Millennium Motoring Club is the Governing Body of Motor Sports within Jamaica appointed by the Federation Internationale de L'Automobile

#### **Table of Contents**

#### **Section 1**

#### **General Regulations**

##### **1.1 General Regulations**

- 1.1.1 Competition Sub-Committee Authority
- 1.1.2 The JMMC Motor Sport Rules and Regulations
- 1.1.3 Administration of these Regulations
- 1.1.4 Application of these Regulations
- 1.1.5 Amendments and Additions to Regulations
- 1.1.6 Compliance with these Regulations
- 1.1.7 Order of Precedence of Regulations
- 1.1.8 Date of Operation
- 1.1.9 Definitions

#### **Section 2**

#### **Organization of Competitions**

##### **2.1 General Administration of Competition**

- 2.1.1 Official Documents
- 2.1.2 Application for an Organizing Permit
- 2.1.3 Minimum requirements to be met
- 2.1.4 Venues
- 2.1.5 Insurance Requirements
- 2.1.6 Advertising and Promotion

- 2.1.7 Postponements, Abandonment or Cancellation
- 2.1.8 Entries
- 2.1.9 Entry Forms

## **2.2 Additional Supplementary Regulations and Programs**

- 2.2.1 Additional Supplementary Regulations
- 2.2.2 Contents of Additional Supplementary Regulations
- 2.2.3 Programs

## **2.3 Conducting an Event**

- 2.3.1 Timing and Scoring
- 2.3.2 Starts and Heats
- 2.3.3 Starting Line
- 2.3.4 Starter's Orders
- 2.3.5 Penalty for a False Start
- 2.3.6 Start Line Judges
- 2.3.7 Heats
- 2.3.8 Publication of Results

## **2.4 Competitors**

- 2.4.1. Entrants, Drivers and Co-Drivers
- 2.4.2. Driver's and Co-Driver's Competition Licenses
- 2.4.3. Grades and Licenses Issued by the JMMC
- 2.4.4. FIA Licenses Application
- 2.4.5. JMMC National License Application
- 2.4.6. JMMC Provisional License Application
- 2.4.7. JMMC Entrant Licenses
- 2.4.8. Validity of Competition Licenses
- 2.4.9. Drivers Medical Responsibility
- 2.4.10. General Conduct of Competitors
- 2.4.11. Responsibility Competitors
- 2.4.12. Alcoholic Beverages, Narcotics and Dangerous Drugs
- 2.4.13. Driver's/Co-Driver's Equipment

## **2.5 Officials**

- 2.5.1. Nomination of Officials
- 2.5.2. Demarcation of Duties
- 2.5.3. Duties of Officials
- 2.5.4. List of Officials

## **2.6 Protests**

- 2.6.1 Reasonableness of Protest
- 2.6.2 Right of Protest
- 2.6.3 Lodging of Protest
- 2.6.4 To Whom Addressed
- 2.6.5 Protest Time Limit
- 2.6.6 Inadmissible Protest
- 2.6.7 Hearing
- 2.6.8 Judgement from a Hearing
- 2.6.9 Publication of the Awards and Prize-Giving

## **2.7 Appeals**

- 2.7.1 Appeal Time Limits
- 2.7.2 Grounds for an Appeal
- 2.7.3 Required Submissions in an Appeal
- 2.7.4 Decision to Hear an Appeal
- 2.7.5 Hearing an Appeal
- 2.7.6 Jurisdiction of the Appeal Board
- 2.7.7 Judgement of the Appeal Board
- 2.7.8 Publication of Appeal Board Judgement
- 2.7.9 Conduct Subsequent to an Appeal Judgement
- 2.7.10 Return of Appeal Fees. Costs

## **2.8 Flags**

- 2.8.1 Flags and their Meaning

These Regulations are intended to assist in the conduct of competitions and to further general safety. They are a guide, and are in no way a guarantee against injury or death to participants, spectators or others. No express or implied warranties of safety or fitness for a particular purpose shall be intended or result from publication or compliance of these regulations. By participation in these competitions all competitors are deemed to have agreed to be bound by these Regulations.

# **Section 1 General Regulations**

## **1.1 General Regulations**

### **1.1.1 Competition Sub-Committee Authority**

The Competition Sub Committee, hereinafter referred to as “the CSC” is delegated the authority to establish, amend and regulate all Motor Sports Competitions, Events or Series sanctioned by the Jamaica Millennium Motoring Club.

### **1.1.2 These Regulations**

So that the authority can be exercised in a fair and equitable manner, the CSC has drawn up these Regulations, hereinafter referred to as “these Regulations”.

### **1.1.3 Administration of these Regulations**

The CSC shall render decisions concerning these Regulations; grant, refuse or withdraw licenses; approve and appoint officials; impose and remove penalties for violation of these Regulations; establish its own procedures; do any and all things which in its judgment are conducive to the well-being of the conducting of competitions held under permits of the JMMC. The CSC decision shall be final and binding upon all parties.

### **1.1.4 Application of these Regulations**

- a) Insofar as there is no conflict with these Regulations, CSC approved Additional Supplementary Regulations shall be deemed to be part of these Regulations.
- b) The headings used in these Regulations are provided as a convenience to the reader and are not to be read into the Regulations.

### **1.1.5 Amendments and Additions to Regulations**

- a) The CSC reserves to itself the right to alter these Regulations and appendices at any time.
- b) Bulletins issued by the CSC form part of these Regulations and are effective on the date issued until these Regulations are in force or unless amended or revoke earlier by the CSC.

### **1.1.6 Compliance with these Regulations**

The organizers of a competition shall ensure compliance with these Regulations insofar as the Regulations indicate. It is a condition of the granting of an organizing permit that the laws of the land shall be complied with, and breach of this condition may invalidate any approvals already given.

### 1.1.7 Order of Precedence of Regulations

- a) The order of precedence shall be as follows:
  - 1) These Regulations and decisions of the CSC.
  - 2) Approved Additional Supplementary Regulations.
  - 3) Instructions from Officials
- b) Where conflict arises between Regulations, the CSC Regulations and decision of the CSC shall prevail.

### 1.1.8 Date of Operation

These Regulations shall come into force and be operative from **December 31 2004.**

### 1.1.9 Definitions

The following definitions are adopted for use in these Regulations and for general use;

**Additional Supplementary Regulations (ASR's)** means Regulations that establish operating procedures for a competition that are drawn up by the organizer of an event and approved by the CSC.

**ASN** means the National Sporting Authority as appointed by the FIA.

**Autocross** means a speed event on a closed course where the results are determined by the fastest time; usually referred to as a Sprint.

**Championship** means a competition or series of competitions or events organized for the purpose of establishing the right to an individual or collective title.

**Co-Driver** means in a stages rally the person normally charged with interpreting the route and timing instructions.

**Competition** means a competitive contest in which cars take part. The competition includes all activities from the opening of registration until the issuance of final results.

**Competitor** means a person whose entry is accepted for a competition or who competes in an event, whether as an entrant, driver or co-driver.

**CSC** means Competition Sub-Committee, appointed by the JMMC.

**Dexterity** in these Regulations means a skill test where the course is marked by pylons and tyres, sometimes referred to as a slalom.

**Driver** means a driver, licensed for competition, named as the driver of a car.

**DSC** means Disciplinary Sub-Committee.

**Entrant** means a person or organization whose entry is accepted for a competition.

**Event Organizer or Organizer** means a group or individual authorized by the CSC to hold an event sanctioned by the JMMC.

**Event** used in context means an entire program of competitions.

**FIA** means Federation Internationale de L'Automobile.

**Force Majeure** means a condition of any kind that creates a situation whereby it is unreasonable to start or continue a competition, or to fully apply a Regulation.

**Hillclimb** means an uphill speed event on a closed course where the results are determined by the fastest time usually referred to as a sprint.

**JMMC** means the Jamaica Millennium Motoring Club, the Governing Body for Motor Sports within Jamaica appointed by the Federation Internationale de L'Automobile (FIA).

**Navigator** means in a navigational rally the person normally charged with interpreting the route and timing instructions.

**OEM** means Original Equipment Manufacturer.

**Official Notice Board** means the place where results are posted.

**Organizing Permit** means a document authorizing the organization of a competition, issued by the CSC.

**Parc Fermé** means the place to which the competitor is obliged to bring his car (s) as foreseen by the ASR's. Inside the parc fermé, only the officials assigned to surveillance may enter. No operation, checking, tuning or repair is allowed unless authorized by the same official. The ASR's of the competition shall specify the place where the parc(s) fermé (s) will be set up.

**Program** means official document prepared by the organizing committee of the sporting competition giving all information for acquainting the public with the details of the competition.

**Race** means a competition in which speed, or the lowest lapsed time, is the essential factor for classification.

**Rally** means road event with an imposed average speed, which is run entirely or partly on roads open to normal traffic. A rally consists of either a single itinerary, which must be followed by all cars, or of several itineraries converging on a same rallying-point fixed beforehand, and followed or not by a common itinerary. The route may include one or several special stages, i.e. events organized on roads closed to normal traffic, and which together determined the general classification of the rally. The itineraries which are not used for special stages are called road sections. Speed must never constitute a factor determining the classification on these road sections.

**Regulations** means these Regulations, ASR's, Bulletins issued by the CSC amending these Regulations and instructions from Officials.

**Sprint** means Hillclimb or Autocross, a speed event on a closed course where the results are determined by the fastest time.

## **Section 2**

### **Organization of Competitions**

#### **2.1 General Administration of Competition**

Jamaica Millennium Motoring Club sanction is required for the organization of any Motor Sport event, series, championship or competition, held in Jamaica, and is reserved for clubs or organizations recognized by, and affiliated to, the Jamaica Millennium Motoring Club.

##### **2.1.1 Official Documents**

All Supplementary Regulations, programs, entry forms and results relating to any event sanctioned by the JMMC shall bear in a conspicuous manner the logo of the JMMC as well as the following announcement: "Sanctioned by the Jamaica Millennium Motoring Club and held under the present Code and under the present Motor Sports Rules and Regulations of the JMMC".

##### **2.1.2 Application for an Organizing Permit**

Every application for an organizing permit shall be sent to the CSC at least one month prior to the date of the proposed event; the CSC may waive this requirement in special cases. The application shall have following attachments:

- i) The names of the persons proposed to form the organizing committee and the address of this committee;
- ii) A draft of the Additional Supplementary Regulations applicable to the event;
- iii) The appropriate fee. In the case of the JMMC having fixed a fee beforehand for the issue of an organizing permit, application must be accompanied by that fee, which will be reimbursed if the permit is not granted.

### **2.1.3 Minimum Requirements to be met**

An organizer shall have the following minimum requirements in effect at all time a speed event is in progress, failing which the proceedings will be halted by the Chief Steward until the minimums are met;

- i) A medical doctor available and equipped at all times to respond to an emergency.
- ii) An ambulanced staff by competent attendants.
- iii) Acceptable fire fighting equipment.

### **2.1.4 Venues**

- i) An organizing permit shall not be issued unless and until the race track or course upon which the event is to be held has been approved by the CSC.
- ii) A competition may be held either on a road or on a track, or on both, but no permit shall be granted by the CSC unless the organizing committee undertakes to obtain the relevant permission from the proper authorities or property owners.
- iii) Competitions taking place on public roads open to normal traffic must conform to the Road Traffic Regulations of Jamaica.

### **2.1.5 Insurance Requirements**

Applicants are required to contact the Management Committee for further information.

### **2.1.6 Advertising and Promotion**



To further the aims and objectives of the JMMC in presenting a responsible and professional image of Motor Sports in general, advertising material and publications shall be in accordance with the laws of the land, in good taste, and shall not be misleading or untruthful.

### **2.1.7 Postponements, Abandonment or Cancellation**

- i) An event shall not be postponed, abandoned or canceled prior to its scheduled start once an organizing permit has been issued by the CSC unless;
  - a) Provisions for doing so is made in the ASR's
  - b) The Chief Steward so orders for reasons of safety or force majeure.

### **2.1.8 Entries**

- a) An entry is a contract between a competitor and the organizing committee. It can be signed by both parties or result from an exchange of correspondence. It compels the competitor to take part in the competition in which they have accepted the run, except in case of duly established force majeure. It binds the organizing committee to fulfill, toward the competitor, all the particular conditions of the entry, with the only reservation that the competitor has made every effort to take part faithfully in the competition concerned.
- b) Once the CSC has issued a permit for an event, the organizers may receive entries. Final entries shall be made in writing on the proper form supplied by the organizing committee. Any entry not accompanied by the proper entry fee shall be null and void. The ASR's may, however, provide for an additional period of time for the nomination of drivers/co-drivers.
- c) Should an organizer accept the entry of a foreign competitor and/or driver who has no authorization from the ASN which issued them with their license or licenses, that organizer would be committing an infringement which, when known to the FIA, would entail such fine as the FIA may deem to impose.
- d) Dates and times for the closing of entries must be mentioned in the ASR's.
- e) Entries may be made by facsimile, at the discretion of the organizer, provided that the fax is dispatched before the time limit fixed for the closing of entries and that it is confirmed by a letter faxed at the same time confirming the entry fee. The time of sending shown on the facsimile will be used as conclusive evidence.
- f) Any entry which contains a false statement shall be considered null and void and the entrant may be judged guilty of improper conduct and moreover the entry fee may be forfeited.

- g) An organizing committee may refuse an entry without having to give a reason for this.
- h) The organizers shall not enter on the program or publish as entered the name of any competitor or driver in respect of whom they have not received a duly authorized entry form or nomination.
- i) Unless it has already been provided for in the ASR's, should the number of entries received exceed the maximum number of competitors laid down in the ASR's, those to be accepted shall be selected either according to the order of receipt of their entries or by means of a ballot, or by another means determined by the CSC.
- j) Should any competitor be eliminated in accordance with Article 2.1.8.i above, they may be accepted as a reserve provided that the prior agreement of the organizing committee has been obtained.
- k) An entry may be withdrawn without penalty if a notice of withdrawal is received in writing by the organizer before the final entry deadline date as stated in the ASR's. In such cases the organizer shall return the entire entry fee, however an entrant or driver accepted to take part in an event who withdraws other than in the above manner or who does not take part in the event, shall, at the discretion of the organizer, forfeit all entry fees.

### **2.1.9 Entry Forms**

Entry forms shall contain the following:

- a) Spaces for full names, addresses, licenses number, type and grade of licenses of entrant and drivers/co-drivers.
- b) Space for full description of vehicle to be entered.
- c) An announcement "Sanctioned by the Jamaica Millennium Motoring Club and held under the present Code and under the present Motor Sports Rules and Regulations of the JMMC".
- d) Spaces for signatories of entrants and drivers/co-drivers for a waiver of liability and / or indemnity declarations.

## **2.2 Additional Supplementary Regulations and Programs**

### **2.2.1 Additional Supplementary Regulations**

- a) For every competition the event Organizers are responsible for drawing up and publishing Additional Supplementary Regulations that need not repeat these Regulations. However, under no circumstances they shall conflict with these Regulations.
- b) No amendments shall be made to the Supplementary Regulations after the beginning of the period for receiving entries, unless unanimous

- agreement is given by all competitors already entered, or by decision of the Stewards of the meeting for reasons of force majeure or safety.
- c) Should any condition(s) contained in the Additional Supplementary Regulations be contrary to these Regulations, it shall be null and void.

### **2.2.2 Contents of Additional Supplementary Regulations**

Additional Supplementary Regulations shall contain;

- a) Nomination of the organizer(s);
- b) The name, nature and definition of the proposed competition(s);
- c) An announcement, accompanied by the JMMC logo; "Sanctioned by the Jamaica Millennium Motoring Club and held under the present Code and under the present Motor Sports Rules and Regulations of the JMMC";
- d) Composition of the organizing committee and address of that committee;
- e) Place and date of the event;
- f) A full description of the proposed competition (length and direction of the course, classes and categories of vehicles admitted, fuel, restriction in the number of competitors, if such limitation exists, etc.);
- g) The dates of opening and closing of entries and how and where they shall be made, and the penalty for late entry if applicable, the amount of the entry fee, conditions under which entries may be refused, and when applicable the passes provided and the cost of additional passes to the entrant;
- h) All relevant information concerning insurance (when necessary);
- i) The dates, times and nature of starts, halts and publication of results;
- j) Licenses requirements;
- k) The times and dates fixed for registration and Technical Inspection;
- l) A detailed list of prizes to be awarded and what championships points shall count towards;
- m) The location of the "Official Notice Board";
- n) The names of the Stewards of the event and the clerk of the course.

### **2.2.3 Programs**

Organizers when publishing or announcing an event program shall include in the program the following information;

- a) An announcement, accompanied by the JMMC logo; "Sanctioned by the Jamaica Millennium Motoring Club and held under the present Code and under the present Motor Sports Rules and Regulations of the JMMC"
- b) Place and date of the event;
- c) A short description and the time table of the proposed competitions;
- d) When available competition number and names of competitors (if pseudonyms are used), they must appear between inverted commas).
- e) A detailed list of prizes assigned to each competition.
- f) The names of the Stewards of the meeting and of the Clerk of the Course.

## **2.3 Conducting an Event**

### **2.3.1 Timing and Scoring**

- a) All timers shall be equipped with stop watches. These watches shall be of the continuously running type, capable of being read to the nearest 1/10 of a second. This will not be construed as making electronic timing equipment unacceptable; however, watches as described shall always be used as a backup source of information.
- b) Timers shall be assigned to vehicle or vehicles according to their capabilities or experience. In some cases more than one timer may be assigned the same car in which case an average may be used to determine the time elapsed.
- c) In qualifying sessions every lap for every vehicle should be timed, however when this is not possible the ASR's shall define the manner in which the timing will be executed.
- d) If it is not stated in the ASR's, in the event of failure of a timing mechanism or force majeure, during qualifying for a race, the Chief Steward shall decide the method by which cars are to be classified. This decision is not subject to protest.
- e) Timing and scoring of rallies will be as stipulated in the Rallysports Regulations, Section 3 within the JMMC Regulations.

### **2.3.2 Starts and Heats**

- a) The start is the moment when order to start is given to a competitor or to several competitors starting together. If timing is employed, this will commence at the start. There are two sorts of starts:
  - i) The rolling start: A rolling start occurs when the vehicle is moving at the moment when the timing begins. For a rolling start,

competitors may be led by a starter in a pace car until the starting figure is given. Therefore, the event will be considered to have started when the leading vehicle other than the pace car crosses the starting line.

- ii) The standing start: A standing start occurs when the vehicle is stationary at the moment when the order to start is given. For vehicles starting singly or in line abreast timing is done by means of a watch or with a timing apparatus not triggered automatically, the vehicle or vehicles shall be placed before the start with that part of the front wheels touching the ground placed on the starting line. The timing shall begin when the signal to start is given.
- b) A competitor shall be deemed to have started at the moment when the order to start is given. Under no circumstances whatsoever shall this signal be repeated.
- c) The ASR's shall define the nature of the start if the option exists.

### **2.3.3 Starting Line**

- a) In competitions with a rolling start, the starting line is the one which, when crossed, starts the timing of the vehicle(s).
- b) In competitions with a standing start, the standing line is the line in relation to which the position of each is fixed, prior to the start.
- c) Starting line before the pits: Once the starting signal is given, a driver will be considered as having completed one lap, the first time they pass the starting line.
- d) Starting line after the pits: Once the starting signal is given, a driver will be considered as having completed one lap, the second time they pass the line.
- e) After final publication of the starting grid for a race, the places of any non-starters shall be left empty, the other competitors retaining their published positions on the grid.

### **2.3.4 Starter's Orders**

- a) Competitors and vehicles are under the orders of the starter from the moment the flag is raised until the moment the flag is dropped.
- b) The movements of the flag may be accompanied or replaced by any other conventional signal.
- c) Any competitor in a race not coming under starter's orders with his vehicle in time shall be deemed to be a non-starter.

### **2.3.5 Penalty for a False Start**

- a) A false start occurs when, before the appropriate signal is given, a competitor under the Starter's orders moves forward from the prescribed position.
- b) In the case of a grouped start in a race, any driver who makes a false start shall be penalized according to the Circuit Racing Regulations. This penalty shall be immediately notified to their pit.
- c) In the case of a single start, any competitor having made a false start shall be penalized according to the Regulation of the type of event. (race, rally, sprint, etc.).

### **2.3.6 Start Line Judges**

One or several judges may be appointed by the organizing committee of a race to supervise the starts. Start line judges shall immediately indicate to the clerk of the course any false starts which may have occurred. In the case of a single vehicle start the starter may act in place of a start line judge.

### **2.3.7 Heats**

A competition may be started in heats, the composition of which must be determined by the organizing committee and be published in the program. The composition of these heats may be modified if required, but only by the Stewards.

### **2.3.8 Publication of Results**

- a) The Chief Scorer/Timekeeper shall after the finish of an event, race, or qualifying session, submit to the Chief Steward for approval and signature, the signed and dated provisional results with the time clearly shown. The Chief Scorer/Timekeeper shall post the provisional results to the official notice board.

## **2.4 Competitors**

### **2.4.1 Entrants, Drivers and Co-Drivers**

- a) Every entrant, if the entrant is not a driver, who participates in a JMMC sanctioned event, must be in possession of a current valid JMMC entrants License.
- b) Every driver or co-driver who participates in a JMMC sanctioned event must be in possession of a valid competition License of the grade that is required for that event.
- c) The JMMC may authorize specific events or types of events for which a competition License is not required.

- d) Application for and granting of Licenses is regulated by the conditions laid down in these Regulations. The holding of a License is a privilege and not a right. A License issued by the JMMC may, for sufficient cause, be withdrawn, suspended, revoked or refused by the CSC at any time.
- e) Application forms for competition Licenses are available from the JMMC.

#### **2.4.2 Drivers and Co-Driver's Competition Licenses**

- a) To be eligible to compete in a JMMC sanctioned event, a driver and/or co-driver must;
  - i) Join and be a member of the JMMC or JMMC affiliated club, or be an invited guest of the JMMC, and
  - ii) Possess a current, valid JMMC or FIA competition license of the grade required for that particular event.
- b) Drivers issued a License by a foreign ASN must possess a letter of authority from their ASN giving permission to compete in Jamaica, and also must possess an International Medical Card (available from their ASN).
- c) At the end of an event drivers and co-drivers should obtain the signature, (Signature cards will be supplied with competition Licenses.), of the Chief Steward attesting to their participation in the event satisfactorily. The signatures obtained at events are necessary for upgrading licenses.

#### **2.4.3 Grades of Licenses Issued by the JMMC**

- a) FIA Grade(s) A, B & C qualify the holder for international events as per Appendix L of the FIA International Sporting Code.
- b) JMMC National Competition Drivers License qualifies the holder for all National events sanctioned by the JMMC.
- c) JMMC National Competition Co-Drivers / Provisional Drivers License qualifies the holder for;
  - i) Navigational rallies
  - ii) Sprints & Dexterities
  - iii) Circuit racing (eligibility as specified in the ASR's of the event)
  - iv) Co-driving & Navigating

#### **2.4.4 FIA Licenses Application**

As per Appendix L of the FIA International Sporting Code.

#### **2.4.5 JMMC National Licenses Application**

Applications for a National License shall:

- a) Be a member of the JMMC or a JMMC affiliated club;

- b) Submit a completed current medical form (available from the JMMC);
- c) Submit two (2) passport photographs;
- d) Submit a letter of recommendation from a club or organization recognized by, and affiliated to; the Jamaica Millennium Motoring Club;
- e) Submit the required fee.

#### **2.4.7 JMMC Entrant Licenses**

Applications for an Entrant License shall submit a letter requesting a License, accompanied by the required fee.

#### **2.4.8 Validity of Competition Licenses**

- a) Jamaican competitors must hold a License issued by the JMMC. Another ASN may issue a license to a Jamaican only after receiving written authorization to do so from the JMMC.
- b) A License granted by the JMMC does not constitute a certificate of competency of the holder.
- c) All competition licenses shall expire on December 31<sup>st</sup> in the year issued.

#### **2.4.9 Drivers Medical Responsibility**

Any License holder who suffers injury or illness that at any time may impair directly, or prejudice in any way, the physical or mental ability to drive a car in speed events, shall report such injury or illness immediately to the CSC, and submit to a medical examination and be re-certified fit for competition before again competing in a JMMC sanctioned event.

A decision made by the medical officer at an event regarding the fitness of a driver for competition is final and not subject to appeal.

#### **2.4.10 General Conduct of Competitors**

Competitors and crew members at a JMMC sanctioned event shall conduct themselves according to the highest standards of behavior and sportsmanship, particularly in relations with other competitors, officials, sponsors and their products, in a manner that shall not be prejudicial to the reputation of the JMMC, promoters, sponsors, organizers, or to motor sport in general. Failure to do so may result in penalties which, if imposed are not subject to appeal.

**For the period one month prior to an event, no competitor, or potential competitor, may practice, pace note or reconnaissance any course or stage to be used for an event, either before or after an entry is made,**



**unless specifically allowed to do so by the ASR's for the event. Any competitor caught in breach of this Regulation may face penalties inclusive of exclusion from the event.**

#### **2.4.11 Responsibility of Competitors**

- a) Entrants and drivers are at all times responsible for the conduct of their crew members and guest, and in turn each of these individuals shall be responsible for their own actions.
- b) An offence committed by an entrant, driver or crew member may be directly chargeable to the driver and result in penalties that may ultimately affect the outcome of an event.

#### **2.4.12 Alcoholic Beverages, Narcotics and Dangerous Drugs**

- a) Consumption of alcoholic beverages by any competitor before the end of day's activities at an event is expressly forbidden.
- b) The use of any narcotic or dangerous drug by any competitor, crew member or official prior to or during a JMMC sanctioned event, is specifically prohibited. The Steward of the meeting may prohibit any individual suspected of being under the influence of any narcotic or dangerous drug from participating in that event and further disciplinary action may be taken by the JMMC.

Any action taken, or penalty applied by the Chief Steward with regard to this Regulation is not subject to appeal.

#### **2.4.13 Drivers Co-Drivers Equipment**

- a) All drivers/co-drivers competing in circuit events, speed events or rally special stages must wear crash helmets which meet one of the following standards:
  - . Snell Foundation **SA 2000** (USA).
  - . British Standards Institution BS 6658-85 type A/FR including all amendments (Great Britain).
  - . SFI Foundation Inc., SFI spec **31.1A** and SFI Spec **31.2A** (USA).
  - . **FIA 8860-2004**Any modifications to the above list will be published in the FIA Monthly Official Bulletin.
- b) A full face helmet with visor must be worn by all occupants of open cockpit vehicles. A full face helmet, face shield or goggles is strongly recommended for occupants of closed vehicles.
- c) **Helmets that fail Technical Inspection may be confiscated for the duration of the event.**

- d) All drivers/co-drivers competing in circuit events and any other event as specified in Appendix L of the International Sporting Code, shall wear flame resistant clothing that comply with the FIA standards.

## **2.5 Officials**

### **2.5.1 Nomination of Officials**

- a) Apart from the officials referred to in Article 2.5.4 the CSC may exercise its right to supervise personally any event governed by these regulations, as well as the right to uphold, if needed, their interests vis-à-vis the organizers of the events.
- b) At least one of the Stewards of the event shall be nominated by the CSC.
- c) The other officials shall be nominated by the organizers, subject to the approval of the CSC.

### **2.5.2 Demarcation of Duties**

An official shall not, at any meeting, perform any duties than those for which they were appointed. They shall not be eligible to compete in any competition at any meeting at which they are acting as an official.

### **2.5.3 Duties of Officials**

- a) The term 'official' comprises the persons, listed in Article 1.4.5
- b) At the event there shall be at least three Stewards of the event and a Clerk of the Course and in the case of competitions decided wholly or partly by time, one or more scorers/timekeepers.
- c) The Stewards officiate as a body under the authority of a Chief Steward expressly designated in the Supplementary Regulations. The Chief Steward of the panel of the Stewards of the event is, in particular, responsible for planning the meetings and ensuring that arrangements are respected. They are also responsible for establishing agendas and drawing up the minutes of the meetings.
- d) In the event of a split ballot, the Chief Steward shall have the casting vote.
- e) The Clerk of the course shall remain in close contact with the Chief Steward of the panel throughout the event in order to ensure the smooth running of the event.

### **2.5.4 List of Officials**

#### **a) The Stewards of the Event**

- i) As a general rule the Stewards of the event will not be in any way responsible for its organization and shall not have any executive duties in connection there with. It follows, therefore, that in the carrying out of their duties, they do not incur any responsibility except to the CSC.
- ii) The Stewards of the event shall sign and send to the CSC a closing report as soon as practicable after the close of the event. This report will include the results of each competition together with particulars of all protests lodged and exclusions they may have to be taken for a suspension or a disqualification.
- iii) The Stewards of the event shall have supreme authority for the enforcement of these Regulations, and Additional Supplementary Regulations and of programs. They shall settle any claim which might arise during an event, subject to the right of appeal provided in these Regulations.
- iv) They shall decide what penalty to enforce in the event of a breach of the Regulations.
- v) In exceptional circumstances, they may amend the ASR's (Article 2.2.1).
- vi) In the event of heats, they may alter the composition or the number of heats.
- vii) They may accept or refuse any correction proposed by a Judge of Fact.
- ix) They may inflict penalties.
- x) They may pronounce exclusions.
- xi) They may prohibit from competing any driver or any vehicle which they consider to be dangerous or which is reported to them by the clerk of the course as being dangerous.
- xii) They may exclude from any one competition or for the duration of the meeting any entrant or driver whom they consider as, or who is reported to them by the Clerk of the Course or by the organizing committee as being guilty of improper conduct or unfair practice.
- xiii) Furthermore, they may order the removal from the course and from its precincts of any entrant or driver who refuses to obey the order of a responsible official.
- xiv) They may postpone a competition in the event of force majeure or for serious safety reasons.
- xv) They may modify the program as to the position of the starting and finishing lines, or in any other manner, if requested to do so by the Clerk of the Course or the organizer in the interests of competitor and public safety.
- xvi) In the event of the absence of one or several of the Stewards of the meeting, they may appoint one, or, if necessary, several

substitutes, especially when the presence of three Stewards is indispensable.

xvii) They may take the decision to stop a competition.

**b) The Clerk of the Course**

The Clerk of the Course, may also be the secretary of the event and may have various assistants, and is responsible for conducting the meeting in accordance with the official program. In particular they shall:

- i) Generally keep order, in conjunction with such security and police authorities as have undertaken to police a meeting and who are more immediately responsible for public safety.
- ii) Ensure that all officials are at their posts and report the absence of any of them to the Stewards of the event.
- iii) Ensure that all officials are provided with the necessary information to enable them to carry out their duties.
- iv) Control competitors and their automobiles and prevent any excluded, suspended or disqualified competitor or driver from taking part in a competition for which they are not eligible.
- v) Ensure that each automobile, and if necessary, each competitor, carries the proper identification numbers in accordance with those in the program.
- vi) Ensure that each automobile is driven by the proper driver and marshal the automobiles in such categories and classes as are required.
- vii) Bring the automobiles up to the starting line in the right order and if necessary give the start.
- viii) Convey to the Stewards of the event any proposal to modify the program or regarding the improper conduct of, breach of rule by, or protest on the part of a competitor.
- ix) Receive these protests and transmit them immediately to the Stewards, who shall take the necessary action thereon.
- x) Collect the reports of the scorers/timekeepers, Technical Inspectors, assistant Technical Inspectors, track or road marshals, together with such other official information as may be necessary for the determination of the results.
- xi) Prepare, or ask the Secretary of the meeting to prepare the data for the closing report regarding the event for which they were responsible for the Stewards' consideration and approval.

**c) The Secretary of the Event**

- i) The Secretary of the event shall be responsible for all documents pertaining to the organization of the event, and all announcements required in connection therewith.

- ii) They shall ensure that the various officials are familiar with their duties and provided with the necessary equipment. If necessary, they shall second the Clerk of the Course in the preparation of the closing report for each competition.

**d) Scorers/Timekeepers**

The principal duties of scorers/timekeepers shall be:

- i) The responsibility for all timekeeping and scoring arrangements for the event, in conjunction with the Secretary of the event, be responsible for the dissemination of results in accordance with these Regulations;
- ii) At the beginning of the meeting, to report to the Clerk of the Course, who will give them the necessary instructions;
- iii) To start the competition, whenever instructed to do so by the Clerk of the Course;
- iv) To use for timing only such apparatus as is approved by the CSC;
- v) To post the results on the official notice board;
- vi) To prepare and sign according to their individual responsibility their reports and to send them, accompanied by all necessary documents, to the Clerk of the Course in the case of a meeting.
- vii) To send, on request, their original time sheets either to the Stewards of the meeting or to the CSC;
- viii) Not to communicate any times or results before posting them on the official notice board, except to the Stewards of the meeting and the Clerk of the Course except when otherwise instructed by the officials.

**e) Technical Inspectors**

Technical Inspectors are entrusted with all checking relating to the mechanical components of vehicles. They shall:

- i) Carry out these checks either before the meeting if requested by the CSC or the organizing committee, during the meeting if requested by the Clerk of the Course;
- ii) Use such checking instruments as may be specified or approved by the CSC;
- iii) Not communicate any official information except to the Stewards of the event and the Clerk of the Course;
- iv) Prepare and sign, under their own responsibility, their reports, and hand them to the authority among those mentioned above who instructed them to draw them up.

**f) Assistant Technical Inspectors**

Assistant Technical Inspectors are entrusted with the checking of the weight of vehicles, dimensions of their bodywork and its accessories, and

also of all documents and safety equipment relating to competitors and drivers. The duties of Assistant Technical Inspectors may be entrusted to the Technical Inspectors. Assistant Technical Inspectors shall:

- i) Exercise their functions either before the meeting if requested by the CSC or by the organizing committee, or by during the meeting if requested by the Clerk of the Course.
- ii) Use such checking instruments as may be specified or approved by the CSC.
- iii) Not communicate any official information to any person except to the CSC. The Stewards of the meeting and the Clerk of the Course.
- iv) Prepare and sign, under their own responsibility, their reports and hand them to the authority among those mentioned above who instructed them to draw them up.

**g) Marshals**

- i) The track or road marshals shall occupy, along the course, posts assigned to them by the responsible official. As soon as a meeting begins, each track or road marshal under the orders of the Clerk of the Course to whom they shall immediately report by any means at their disposal (telephone, signals, courier etc.) all incidents or accidents which might occur along the section for which they are responsible.
- ii) Flag marshals are specifically entrusted with flag signaling. They may also be track or road marshals.
- iii) At the end of each competition, all track and road marshals must give the clerk of the course a written report on the incidents or accidents recorded by them.
- iv) During competitions, and unless otherwise instructed by the clerk of the course, track or road marshals shall, as far as possible, inform the central bureau of information concerning the order in which competitors have passed their post. This shall be effected lap by lap in the case of a closed circuit.

**h) Judges**

- i) **Start Line Judges**  
One or several Judges may be appointed by the organizing committee of a race to supervise the starts. Start Line Judges shall immediately indicate to the Clerk of the Course any false starts which may have occurred.
- ii) **Finish Line Judges**  
In a competition where a decision has to be given as to the order in which competitors cross a finish line, a Finish Line Judge shall be nominated to give such a decision.
- iii) **Judges of Fact**

In a competition where a decision has to be given whether or not a competitor has touched or crossed a given line, or upon any other fact of the same type which has been laid down in the Supplementary Regulations for the competition, one or several Judges of Fact shall be nominated to be responsible for one or several of these decisions.

- iv) Assistant Judges  
Each of the above Judges may have an Assistant Judge appointed to assist them, or in the case of absolute necessity to replace them, but in the event of disagreement the final decision shall be given by the Judges of Fact themselves.
- v) Video or Electronic Systems  
The Stewards may use any video or electronic systems to assist them in reaching a decision. The Stewards may overrule Judges of Fact.
- vi) Protests  
No protest against the decisions of a Finish Line Judge or of a Judge of Fact shall be admitted concerning a question which they have been officially appointed to decide. The decisions of these Judges are final, but they shall not in themselves constitute the official classification because they have taken no account of the conditions under which the competitors have completed the course.
- vii) Mistakes  
If any Judge considers that they have made a mistake they may correct it, subject to this correction being accepted by the Stewards of the meeting.
- viii) Facts to be Judged  
The Supplementary Regulations for the competition must indicate which facts are to be judged by the Judges of Fact. The Judge of Fact on these points must be named in the official program
- ix) Reports  
At the close of the meeting each Judge shall send to the Clerk of the Course a report of their declarations.

## **2.6 Protests**

The protest & appeal procedures outlined in these Regulations have to be exhausted before any person may contemplate legal action relating to matters of a sporting nature.

### **2.6.1 Reasonableness of Protest**

- a) The right to protest allowed in Regulation 2.6.2 shall be predicated on a protest being well-founded. The Chief Steward shall review submitted protests and deem them well-founded or not.
- b) A protest can only be lodged by a competitor.
- c) A well-founded protest is:
  - i) Reasonable and
  - ii) Logical and
  - iii) Based on relevant facts and
  - iv) Supported by relevant evidence.

For clarity, a fact is defined as something that can be proven, and evidence is defined as that which supports fact, logic or reason.
- d) The onus is at all times on the competitor, as the protestor, to establish the exact terms of a protest, and clearly not on the Chief Steward or other officials.
- e) Hearsay, conjecture and unsupported opinion may be considered vexatious. Vexatious is defined as; of little or no significance or importance, annoying, disturbing.
- f) Protests that are deficient in reason, logic, facts or evidence may be deemed as not well-founded, and may be denied and the protest fee retained.
- g) Protests that are deemed not well-founded may also be vexatious and may be denied. In such instances the protest fee shall be retained, and further penalties may be applied.

### **2.6.2 Right of Protest**

- a) The right to protest lies solely with the competitor who may consider themselves aggrieved by any decision, act or omission of a promoter, organizer, competitor, entrant, official or other person connected with any competition, in which they are taking part.
- b) Nothing in this Regulation shall affect or prejudice the right of any official to take such action deemed proper in any circumstances, regardless of whether a protest has been lodged.
- c) Decisions of any Judge of Fact are not subject to protest.
- d) Decisions of the Chief Steward are not subject to protest, only appealable.
- e) A competitor wishing to protest against more than one fellow competitor must lodge as many protests as there are competitors involved in the action concerned.

### **2.6.3 Lodging of Protest**

Every protest shall be in writing and accompanied by a fee, the amount of which shall be equal to the entry fee of the event. This fee may only be returned if the protest is upheld.



#### **2.6.4 To Whom Addressed**

Protest arising out of an event shall be addressed to the clerk of the course or their assistant if such exists.

In the absence of the Clerk of the Course or their assistant such protests should be addressed to any of the Stewards of the meeting.

#### **2.6.5 Protest Time Limit**

- a) Any protest concerning the validity of an entry, qualification of a competitor or vehicle or any other matter that could reasonably be expected to be known before the start of an event must be submitted within 30 minutes after the closing of the technical inspection.
- b) Protests against a handicap or make up of a heat must be lodged at thirty (30) minutes before the start of the competition or heat as the case may be.
- c) A protest against a decision of a Technical Inspector or weighing official shall be lodged by the competitor in question immediately after such decision has been made.
- d) Protests against any error or irregularity occurring during an event, referring to the non-compliance of vehicles with the regulations and concerning the classification established at the end of an event shall, except in circumstances which the Stewards of the meeting consider as physically impossible, be made within thirty minutes of the official publication of the results on the notice board. Competitors shall be advised in advance of the place and time of such a publication by the ASR's. Should it be impossible for the organizers to publish the official results as stated, they shall issue, at the time and place fixed, accurate details concerning the measures they intend to take regarding the classification.
- e) However, protest time limits for specific types of events, (i.e. rally, sprint, dexterity, circuit racing, etc.) may vary and the time limits will be stated in the relevant section of these Regulations.
- f) The Stewards of the event shall treat all protests as urgent.
- g) In the case of a split vote amongst the Stewards of the event, the Chief Steward shall have the casting vote.

#### **2.6.6 Inadmissible Protest**

Protests against decisions made by the Finish Line Judges and Judges of Fact in the exercise of their duties, as laid down in Article 2.5.4 h

A single protest against more than one competitor will not be accepted.

### **2.6.7 Hearing**

- a) The Chief Steward shall hear all protests. All parties concerned shall be given notice of the time, not to exceed 24 hours after the finish of the event, and location of the hearing which shall take place as soon as is practical after the protest is lodged. The hearing shall not be held sooner than 60 minutes after maximum lateness allowed for the last car to arrive at the finish line, in the case of a rally.
- b) Before hearing any protest the Chief Steward shall determine if the protest was submitted in full accordance with these Regulations. Failure of the protester to comply with all of these conditions shall result in the return of the protest without hearing and the retention of the protest fee by the JMMC.
- c) The onus is always on the protestor to properly present a protest, and no claim for lack of knowledge of these Regulations or the ASR's shall be allowed.
- d) Protestors at a hearing shall themselves (or with the assistance of a designated translator if language difficulties exist) state their case in person and are entitled to call witnesses and shall be responsible for the prompt availability of any witnesses called. Should a protestor designate a translator for purposes of stating or arguing a protest, the words of the translator shall be deemed to be those of the protestor.
- e) In the absence of any concerned party or their witnesses, judgement may be made by default.

### **2.6.8 Judgement from a Hearing**

- a) If judgement cannot be given immediately after the hearing of the parties concerned, they must be advised of the place and time at which the decision will be given.
- b) If the Stewards have reached a decision, the reply shall contain their decision and shall state specifically what changes, if any, has to be made to the scoring as a result of the decision.
- c) If the Stewards wish to obtain further evidence (e.g. on the route), the reply shall state that their decision has been deferred.
- d) If any decision of the Stewards is deferred (as in Article 2.6.8 Item c above), a final ruling shall be presented to the organizer within 48 hours of the end of the event. Any resulting changes in the scoring shall be included in the results (provisional results in the case of rallies).
- e) If the scores were not posted as specified in the ASR's, or if a protest decision was deferred, the date of a hearing to review any protest submitted hereafter shall be included in the Provisional Results.

These protests shall be limited to scoring matters or those originating from a decision on a deferred protest. The hearing shall be held no later than seven (7) days after the end of the event and shall be closed (i.e. only Stewards shall attend).

At the hearing, the Stewards shall first verify that each protest to be considered was properly submitted with the corresponding fee and shall then rule on it.

The decision of the Stewards shall be presented to the organizers within 24 hours after the hearing and shall state what changes, if any, are to be made to the scoring as a result of the decisions.

The organizers shall then post a second set of Provisional Results for all competitors no later than ten (10) days after the end of the event.

- f) The Chief Steward shall keep a record of all protests and replies and forward same to the CSC for filing in the Protest Register.
- g) All parties concerned shall be bound by the decision reached, subject to the conditions of the appeal laid down in these Regulations but neither the Stewards of the meeting nor the JMMC shall have the right to order that a competition be re-run.

#### **2.6.9 Publication of the Awards and Prize-Giving**

The prize-giving shall not begin until at least half an hour has elapsed after the official publication of the results.

A prize won by a competitor against whom a protest has been lodged must be withheld until a decision has been reached on the subject of the protest.

Moreover in the event of any protest being lodged whose outcome might modify the classification of the competition, the organizers shall only publish a provisional classification and shall withhold all prizes until a final decision concerning the protest (including appeals) has been reached.

However, when a protest may affect only part of the classification, such part as is not affected by the protest may be published definitively, and the corresponding prizes distributed.

#### **2.7 Appeals**

- a) Competitors shall have the right to appeal against a sentence or other decision pronounced on them by the Stewards of an event before the CSC. Notice of Intention to Appeal shall be given in writing to the Chief Steward within one (1) hour of the publication of the decision and shall be

accompanied by a fee, the amount of which shall be equal to the protest fee.

- b) Notice of appeal shall not affect the validity or operation of any decision, penalty or sentence appealed against. However the Chief Steward if notified of an intention to appeal a decision may permit a competitor to continue in an event if the matter arises during the course of the event. The decision is not appealable and in any event the Chief Steward shall order awards which may be affected by the outcome of the appeal to be withheld pending the decision of the Appeal Board.

### **2.7.1 Appeal Time Limits**

- a) The appeal itself must be submitted in typewritten form or it shall be denied without further action. It must be submitted to the CSC and must be received within forty eight (48) hours after the decision of the Stewards was handed down.
- b) An appeal properly made may be withdrawn prior to the appointment of the appeal board with the permission of the CSC. The appeal fee less 20%, which is an administration fee, shall be returned to the appellant.

### **2.7.2 Grounds for an Appeal**

- a) The grounds for appeal are either the following allegations;
  - i) The Chief Steward has dealt with the case using improper procedures.
  - ii) New substantial evidence or expert testimony relating to the case that was not available at the time of the original protests hearing has become available.
- b) For greater clarity, an appeal will not be allowed for a repeat presentation of the original protest.

### **2.7.3 Required Submissions in an Appeal**

- a) An appeal shall specify in full:
  - i) The reasons claimed that the Chief Steward acted improperly, clearly indicating which part(s) of any Regulations that are considered to have been enforced in a manner that was not fair or equitable to the appellant.
  - ii) A complete description of any new evidence and/or expert testimony and how it may affect the original protest decision.
- b) Appeals must contain sufficient information to allow the CSC to determine whether or not an appeal shall be heard. Failure of the appellant to do so will result in the forfeiture of the appeal fee.

- c) A list of witnesses that the appellant may wish to call, a description of their involvement in the incident in question, and the general nature of their testimony.
- d) The appeal shall bear the signature of the appellant or an authorized representative of the appellant accompanied by a letter of authorization naming the representative as being able to act on behalf of the appellant.

#### **2.7.4 Decision to Hear an Appeal**

- a) The CSC will make a decision as to whether or not an appeal is well-founded and will be heard by an Appeal Board. Should an appeal not be heard, the appeal fee shall be returned, less 20% which is an administration fee.
- b) It may also be the case that an appeal is deemed vexatious in nature and a decision may be made to deny the appeal on this basis, in which case the entire appeal fee will be forfeited and further penalties may be applied.
- c) Decisions made under this Regulation shall be final and binding upon the appellant and not subject to further action by any party.

#### **2.7.5 Hearing an Appeal**

- a) Subject to the provisions of Regulation 2.7.4, the Appeal Board will provide notice to the appellant indicating the time and place for the hearing. It is incumbent upon the appellant to assemble any witnesses at the appointed place.
- b) The board shall use their best efforts to convene and hear the appeal no later than seven (7) days after a decision to hear an appeal.
- c) At an Appeal Board Hearing all parties concerned are entitled to call witnesses and present evidence. They may present their case personally, or with prior permission to the board submit the case to the Board entirely in writing without personal appearance.
- d) The Appeal Board can hear evidence in any manner it deems appropriate, relevant and necessary.

#### **2.7.6 Jurisdiction of the Appeal Board**

An Appeal Board comprising of at least three (3) people shall be appointed by the CSC, no member of the Appeal Board should have taken part as competitor, official, organizer, promoter or sponsor in the competition concerning the decision to be given, or who have already been directly concerned in the matter under consideration.

#### **2.7.7 Judgement of the Appeal Board**

- a) After considering the material deemed to be relevant, the Appeal Board shall meet privately to reach a decision and prepare a written judgement. The Appeal Board may decide that an existing penalty be nullified, mitigated, affirmed, increased or a different penalty imposed.
- b) The decision of the Appeal Board shall be presented to the organizer within twenty four (24) hours of final judgement.
- c) The decision of the Appeal Board shall be final and binding on all parties.

### **2.7.8 Publication of the Appeal Board Judgement**

The JMMC shall have the right to publish or cause to be published a judgement of an appeal and to state the names of all parties involved. The persons or bodies referred to in such a notice shall have no right of action against the JMMC or against anyone printing or publishing said notice.

### **2.7.9 Conduct Subsequent to an Appeal Judgement**

Any participant who, subsequent to an Appeal Board judgement, discredits or attempts to discredit an Appeal Board judgement and by so doing discredits motor sports generally, the JMMC, promoters, sponsors, or event organizers is subject to a disciplinary hearing.

### **2.7.10 Return of Appeals Fees. Costs**

In giving a decision on the appeals brought before them, the Appeal Board shall decide, according to the decision, to award the costs which shall be calculated by the preparation of the case and the meeting of the courts. The costs shall be constituted by these expensed alone, to the exclusion of the expenses or defense fees incurred by the parties.

## **2.8 Flags**

### **2.8.1 Flags and their Meaning**

- a) Green Flag
  - i) Road clear
  - ii) Start of a race
- b) Yellow Flag
  - i) Standing Yellow: Caution, no overtaking until past the danger zone.
  - ii) Waved Yellow: Extreme Caution, no overtaking until past danger zone.
- c) Blue Flag

Another competitor is following you very closely or is trying to overtake you. This flag may be displayed standing or waving, depending upon the speed with which you are being overtaken.

- d) Yellow with Vertical Red Stripes Flag  
A slippery condition exists in the area of the flag station
- e) White Flag  
Caution, slow moving vehicle(s) ahead.
- f) Black Flag  
Report to the Pits.
- g) Red Flag  
Cease racing, come to an immediate and controlled stop at the side of the track
- h) Black and White Checkered Flag  
End of a race or session.



# **JAMAICA MILLENNIUM MOTORING CLUB**

## **Section 3 The Rallysports Regulations**

The Rallysports Regulations is a part of the JMMC Motor Sports Rules and Regulations. The Rallysports Regulations shall be used in conjunction with Sections 1 and 2 of the Motor Sports Rules and Regulations (also known as the General Regulations).

### **Table of Contents**

#### **Section 3 Rallysports Regulations**

##### **3.1 The Rally Code**

- 3.1.1 General Principle
- 3.1.2 Competitors
- 3.1.3 Vehicles

##### **3.2 The Route**

##### **3.3 Additional Supplementary Regulations (ASR's)**

- 3.3.1 Contents of the Rally ASR's

##### **3.4 Route Instructions**

- 3.4.1 Contents of the Route Instructions

##### **3.5 Abbreviated Instructions and Terms**

- 3.5.1 Meaning of Instructions
- 3.5.2 Odometer Check

##### **3.6 Special Stages**



3.6.1 Regulations for Special Stages

### **3.7 Controls**

3.7.1 Types of Controls

3.7.2 Location of Controls

3.7.3 Control Procedure

3.7.4 Wrong Direction/Approach

### **3.8 Timing**

3.8.1 Time Regulations

### **3.9 Scoring and Results**

3.9.1 Scoring

3.9.2 Assessment of Performance

3.9.3 Results

3.9.4 Protest Time Limits

3.9.5 Points and Awards

### **3.10 Officials**

3.10.1 Duty of Officials

3.10.2 The Chief Steward

3.10.3 The Clerk of the Course

3.10.4 The Secretary of the Event

3.10.5 The Chief Scorer

### **3.11 Conducting a Rally**

3.11.1 Administration of The Rally

3.11.2 Official Notices

## **Section 3 Rallysports Regulations**

### **3.1 The Rally Code**

#### **3.1.1 General Principle**

- a) The Rally Code shall apply to all rallies. The Rally Code is intended to provide a uniform method of handling events and to ensure the safety of

- entrants and spectators. The rules contained herein, in junction with the JMMC Motor Sport Rules and Regulations, shall apply to all rallies sanctioned by the Jamaica Millennium Motoring Club.
- b) All rallies will be governed by the following in the priority of their listing:
    - i) The Road Traffic Act of Jamaica.
    - ii) These Regulations and the decisions of the CSC.
    - iii) The ASR's issued by the Organizers of the event.
    - i) Written instructions issued by the Organizers that may hereinafter be referred to as Official Instructions.
  - c) Any competitor observed, by an official, to be driving recklessly or displaying unsportsmanlike conduct on or near the route, or receives notice of prosecution for a traffic violation while participating in a rally, may be prohibited from further participation in the event and further disciplinary action may be taken by the JMMC.

### **3.1.2 Competitors**

- a) All competitors shall have a valid competition license of the required grade as stated in the ASR's.
- b) A rally crew shall consist of:
  - i) For international, invitational and stage rallies, two persons nominated on the official entry form as driver and co-driver / navigator.
  - ii) For novice rallies the ARSs may allow a maximum of three (3) persons or the licensed capacity of the vehicle whichever is less.
- c) No changes in a crew or vehicles will be permitted after the start of the rally. Any changes in crew after entries have closed must be approved by the Organizers.
- d) The following documents, valid for the duration of the event, shall be shown to the rally officials at registration:-
  - i) Driver's license for any crew member registering as a driver.
  - ii) Valid competition license of the required type or grade.
  - iii) Vehicle registration papers or title.
  - iv) Certificate of Fitness and Insurance. (For vehicles registered in Jamaica only).
- e) All competitors and officials must sign a liability waiver document which shall be in a form approved by the JMMC.

### **3.1.3 Vehicles**

- a) All vehicles shall have four (4) load carrying wheels arranged in normal automotive fashion.

- b) On all vehicles at least two (2) wheels shall be used to provide steering and at least two to provide propulsion. The same two wheels may provide both.
- c) All competing vehicles must be road worthy and shall be subject to a Technical Inspection to determine the function and adequacy of:-
  - i) Steering components.
  - ii) Braking Systems.
  - iii) Stability of driver's and co-drivers seat.
  - iv) Horn.
  - v) Windshield wipers.
  - vi) All legally required lights, including signal lights.
  - vii) Exhaust System.
  - viii) All mandatory safety equipment (correct standards and installation).
  - ix) Tyres including spare tyre(s).
  - x) Fuel system and components.
- b) It must be possible to turn off all high-beam, head lights, driving lights and spot lights from a single low-beam headlight switch.
- c) All vehicles must be fitted with two (2) forward facing green clearance lights to be illuminated during the hours of darkness on events which may require driving during the hours of darkness.
- d) If the vehicle has a back-up light (reverse light) operated by a manual switch, a warning light on the dashboard must come on whenever the back-up light is turned on.
- e) The mounting of maneuverable search lights and lights behind the front axle are forbidden.
- f) Any number or identification used for an event must be removed promptly when a competitor is no longer competing in an event.
- g) A vehicle may only be moved by its own power, the physical efforts of its crew or by gravity except when it constitutes a blockage of the route. Violation of the rule may result in exclusion from the event.
- h) For Stage Rallies and Speed Sections the classification as specified in Section 6.1.2 of the JMMC Regulations shall apply.
- i) In Stage Rallies and Rallies that include Special Stages, all vehicles shall comply with the Mandatory Safety Requirements as specified in Section 6.1.1 of the JMMC Regulations.

### **3.2 The Route**

- a) The route must be carefully chosen to ensure that the competitors are not kept circulating in one locality for a long period of time. Built up sections and busy roads must be used for transport sections only. All efforts must be made to avoid arousing public opinion against rallying.

- b) Two (2) lane roads may not be used for rally traffic that is traveling in both directions at the same time unless specifically stated in the route instructions.
- c) Gas stops of not less than 15 minutes must be provided not more than 160 kilometers apart unless otherwise stipulated in the ASR's.
- d) The minimum distance of a rally shall be 160 kilometers unless otherwise stated on the official competitions calendar.
- e) Rally distance shall be deemed to be the total length of the rally route between the start of the first section and the final control of the last section during which a competitor is required to keep track of the time and mileage. Special Stages and other tests shall be included in the total published length of the event.
- f) No person should drive for more than 320 kilometers or eight (8) hours continuously, whichever comes first, without relief thereafter. There shall be a prescribed rest period of not less than 10 minutes for each hour driven (rounded down to the previous hour). A gas halt may be included in this rest period. However, time spent at prior gas halts may not be used to reduce this prescribed rest period.

### **3.3 Additional Supplementary Regulations (ASR's)**

#### **3.3.1 Contents of the Rally ASR's**

The Rally ASR's shall contain the following information in addition to those stipulated in Section 2 Article 2.2.2.

- a) The names, addresses and telephone numbers of:
  - i) The Organizers.
  - ii) The Secretary of the event.
  - iii) The Chief Steward
  - iv) The Clerk of the Course.
- b) The names of the following:
  - i) Chief Technical Inspector
  - ii) Chief Scorer
- c) The locations of any meal, gas rest stops, where applicable.
- d) Approximate due time of arrival of first vehicle at any gas, meal and rest stops and at the finish, where applicable.
- e) Identification of the official map for the rally. If competitors are to provide their own copy, this must be stipulated.
- f) The method of determining starting positions.
- g) The amount of individual and team entry fees. If fees include the cost of any food, fuel, accommodations, etc., it must be so stated.
- h) The maximum earliness or lateness permitted in the rally.

- i) Scoring details including all items for which penalty may be imposed and the value thereof if different from these Regulations.
- j) Any condition of eligibility of vehicles, crew equipment in addition to those imposed herein.
- k) Categories of classes that are to be used.
- l) A list of all unusual equipment necessary to solve route instructions (e.g. compass).
- m) The method of breaking ties, if different from that specified in these Regulations.
- n) Any numbering or identification to be provided by the competitor.
- o) If any special stages are to be included, it must be stated.
- p) Information regarding the odometer checks.
- q) Any other regulation which the organizers, promoters and/or the JMMC may wish to apply to the rally. These additional regulations may not be in conflict with these Regulations unless specified authorization has been from the CSC.

### **3.4 Route Instructions**

#### **3.4.1 Contents of the Route Instructions**

The route instructions shall be applied in the following manner:

- a) All instructions pertaining to route or timing must be in writing and all route instructions must be typed.
- b) All landmarks or signs referred to in the instructions shall be clearly visible and legible from the front seat of the car proceeding in the correct direction of travel and under anticipated rally conditions.
- c) All references to signs shall be spelt and worded in the signs themselves.
- d) To ensure that each competitor receives a complete and legible set of route instructions, the sheets must be numbered "1 of 5", "2 of 5" etc. and handed out not less than two (2) minutes in advance of starting so that competitors will have an opportunity to verify that they have a complete and legible set.
- e) A crew's departure from the starting line of a section covered by a specific set of instructions shall be construed as evidence that they are satisfied with the route instructions issued to them.
- f) Where no specific instruction is given, a competitor shall continue on the road on which he is traveling as long as the road is clearly and unambiguously defined. For example, the competitor shall stay on the same road surface, named highway, numbered highway, street or road, follow directional arrows (such as "one way" signs), stay on the road protected by "Stop" or "Yield" signs etc. Where any doubt exists, a specific instruction must be given.

- g) When the term "caution" is used, a description of the hazard and a mileage must be given. Cautions shall be graded as Single, Double or Triple depending on the degree of severity.
- h) **Section** is a major portion of a rally, extending between rest, meal or gas stops and is composed of one or more legs.
- i) **Leg** is a sub-division of a Section extending between time controls.
- j) **Intersection** is any meeting or crossing of roads. This definition includes the following types:-
  - i) Y is an intersection of two (2) or more roads in the general shape of the letter "Y" requiring a turn being substantially less than 90 degrees. If the opportunities are not of equal composition or stature, a clarifying instruction must be used.
  - ii) **Triangle** is an intersection of two (2) or more roads in the general shape of a triangle, including within the intersection a generally untraveled grass, gravel or other surface normally used to control the flow of traffic. Slip roads on such intersections shall not be considered to be opportunities unless a clarifying instruction is used.
  - iii) **A Slip Road** is deemed to be any access or exit lanes (filter lanes) forming a portion of a single road at its junction with another/other road(s). For example, in the diagram below, roads A and B shall be deemed to be Slip Roads:-

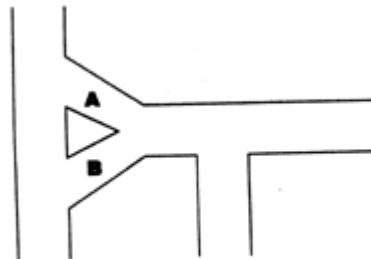

### 3.5 Abbreviated Instructions and Terms

#### 3.5.1 Meaning of Instructions

- a) The following abbreviations and/or terms shall be considered standard:
  - i) **R** means right or turn right
  - ii) **L** means left or turn left
  - iii) **SO** means straight on.
  - iv) **T** means "T" intersection (to be qualified as L @ T or R @ T).
  - v) **SS** means Stop Sign, or Special Stage.
  - vi) **O** means Roundabout (to be qualified as to L @ O, R @ O, etc.)
  - vii) **AL** means Acute Left
  - viii) **AR** means Acute Right
  - ix) **BL** means Bear Left

- x) **BR** means Bear Right
- xi) **TL** means Traffic Light; a light for the control of traffic having more than one (1) colored lens facing the competitor's line of travel, whether it is working or not.
- xii) **N** means North
- xiii) **S** means South
- xiv) **E** means East
- xv) **W** means West
- xvi) " \_\_\_\_\_ " means Full text of a sign
- xvii) **AFTER** means an intersection or Instruction using the work "**After**" shall be executed at the first opportunity after the landmark or point mentioned in the same instruction.
- xviii) **AT @** means a landmark or point used in conjunction with the word "**at**" or symbol "@" shall be located in the immediate vicinity of the point of execution or the referenced instruction.
- xix) **BEFORE** means any point referenced or used in conjunction with the word "**Before**" must be clearly visible from the execution point of the referenced instruction.
- xx) **OPPORTUNITY** means Roads on the ground to be taken into account for the possible execution of an instruction. Normally, opportunities shall only include paved roads unless the ASR's or Route Instructions stipulate otherwise. All one-way roads regardless of direction must be regarded as opportunities.
- xxi) **NON-STOP** means a Section of Leg during which competitors may not stop within sight of control without the risk of incurring the penalty specified. Competitors must stop at controls located in, or at the extremities of, such a Section or Leg. They must also obey road traffic instructions and laws (e.g. Stop Signs, Give Way Signs etc.). However, obvious balking at these instructions may also incur penalty.
- xxii) **OM** means **Overall Mileage**; the distance from the start of any Section.
- xxiii) **IM** means Interim Mileage; the distance from the previous Time Control.
- xxiv) **INT** means Intermediate Mileage; the distance from the previous Instruction.
- xxv) **INSERT** means an instruction to be inserted at a point or mileage specified. Inserts may not be "hidden" in the body of the instructions but must be prominently located at the beginning of the instructions for the Section to which it/they apply.
- xxvi) **SSS** means Special Stage Start.
- xxvii) **MST** means Maximum Stage Time.
- xxviii) **FF** means Flying Finish.
- xxix) **!** means Caution, potential danger.

- xxx) !! means Serious Caution, danger.
  - xxxii) !!! means Extreme Caution, very dangerous, **DO NOT IGNORE**.
  - xxxiii) //// means Exposure from precipice, gully, canal, etc.
  - xxxiv) – means Secondary Road.
  - xxxv) vv means Downhill
  - xxxvi) ^^ means Uphill
- b) If any additional abbreviations/terms are to be used, a glossary must be given in the ASR's.
  - c) In the interest of safety, organizers shall avoid the use of signs which are obscure, small, and difficult to see at rally speeds or during the hours of darkness or which are appreciably removed from the rally route. **Sign design must be in consideration of persons who are colour-blind.**
  - d) The maximum average speed allowed at any point in a rally, other than a special stage, shall be 15% less than the legal maximum speed at that point and must be based on statute miles within +/- 2% except in such cases where TCs are disclosed and the organizers have stated that this factor has been taken into consideration.
  - e) The route instructions must provide for pick-up points, with given official time and overall mileage, at least every 40 kilometers. The location of these recovery points and direction of approach and departure must be defined in such a manner that they can be:
    - i) Located on the official map(s) for the rally.
    - ii) Easily related to the route instructions.
  - f) All competitors shall receive identical route instructions with the exception of the "Rabbits & Hares Rally" when Rabbits shall receive a simplified version of the Hares instructions.
  - g) Route instructions shall not be issued so far in advance as to permit any competitor to practice any part of the route, **unless so noted in the ASR's.**
  - h) All instructions shall be made available to all competitors an equal amount of time before they are due to start the section of the rally to which they apply (normally 2 minutes). Maps may be issued 15 minutes prior to due start time of car 0.
  - i) In the case of an error or discrepancy in the instructions, the competitors shall go to the next pick-up point. All of the controls between the error and the pick-up point shall be eliminated and the competitors shall be given the departure time from the control after the pick-up point which shall be converted into a Route Control. This regulation shall apply in the case of a competitor's protest being upheld or at the discretion of the Chief Steward.

### 3.5.2 Odometer Check



Each rally must provide a specific and readily identifiable odometer check. The following check is provided by the CSC.

- a) This check is 13.16 kilometers on the circuit comprising of Old Hope Road, Barbican Road, Grants Pen Road, Shortwood Road, Constant Spring Road, Half Way Tree Road, Old Hope Road – when traveling in an anti-clockwise direction.

### **3.6 Special Stages**

#### **3.6.1 Regulations for Special Stages**

- a) A special stage is an elapsed time segment of the route where there are no average speeds or speed limits.
- b) Special stages shall be clearly identified in the route instructions, with mileage and times for start and finish controls.
- c) Cars will be started in the order of their arrival at the start of the special stage. On arrival, competitors must report immediately to the start marshal and must be prepared to start without delay.
- d) Competitors shall start the Special Stage with a separation of no less than one (1) minute.
- e) The portion of the route comprising the Special Stage must be closed to all traffic other than competing vehicles.
- f) Crash helmets and seat belts must be worn by each member of the crew during a special stage, and smoking is not permitted. A 50 millimeter maximum opening is allowed for windows, unless the vehicle is fitted with an approved properly secured racing mesh, at which point the window may be left open.
- g) There must be continuous communication between the start control, the finish control and the stop control.
- h) A vehicle equipped to treat automobile accident victims should be standing by at the start control for all competitors. The vehicle must be operated by trained personnel equivalent to "Registered Nurse" or better. It is strongly recommended that a medical doctor be in attendance.
- i) Rallies containing special stages must be covered by land owners risk and third party liability insurance.
- j) Written permission must be obtained from the proper authorities if the special stage is held on public roads. The appropriate public notices must be posted in the media and along the road to be used as required by the authorities. Assistance should be sought in advance from the police to assist in the closing of the road.
- k) If the special stage is run on private property, consent in writing must be obtained from the property owner.
- l) The finish control shall be a Flying Finish and clearly marked.

- m) The stop control shall be clearly marked and must not be situated less than 0.25 kilometers after the flying finish.
- n) Times for all competitors will be recorded to the nearest second at the Flying Finish and relayed to the stop control along with the number of the car and brief description of same by radio. As a back up, these times and vehicle numbers must be recorded on a Marshal's Sheet at both controls.
- o) In addition to the route instructions, all special stages may be marked with supplementary directional arrows placed so as to help the competitors to stay on the proper route. However, route instructions will prevail in all circumstances.
- p) Allowance for special stage must be a minimum of five (5) minutes in excess of the average time taken to complete the test as determined by the organizer. This allowance must be clearly indicated in time keeping instructions.
- q) Pick-up points for OM and IM mileages after each special stage must be given and should be embodied in the instructions so as to enable competitors to correct for any wheel spin errors which may have occurred.
- r) Competitors shall not traverse a special stage or part thereof in the opposite direction of rally traffic.

### **3.7 Controls**

#### **3.7.1 Types of Controls**

The following types of controls are recognized:

- a) Time Control (TC) is a control at the start and the finish of a Leg. A time and direction of approach are recorded.
- b) Elapsed Time Control (ETC) is a control at the start and finish of an elapsed time segment of the route i.e. start/finish of Special Stages. Elapsed Time Controls shall be utilized solely to determine the performance of the competitors within said segments of the route and cannot be used for other scoring purposes, i.e. Route Controls or Time Controls.
- c) Route Control (RC) is a control used to ensure that the competitor is on the correct route. Direction of approach is recorded. No time need be recorded.
- d) Off Route Control (ORC) is a control used to penalize competitors for being on the incorrect route. No time need be recorded.
- e) Start Control is a control at the start of a Section. The competitor's starting time is his Time Out for scoring purposes.
- f) Route Check is an unmanned route control and shall not be used in Championship Rallies nor shall route questions be used.

### **3.7.2 Location of Controls**

- a) No controls may be located so as to interfere with traffic or create a driving hazard.
- b) No controls may be placed in the following locations, with the exception of meal, gas and rest stops:
  - i) On a main highway (e.g. Spanish Town ring road) or heavily trafficked road (e.g. Barbican Road, Barnet Street).
  - ii) Within a residential area (with the exception of Route controls) for major rallies.
  - iii) Immediately after a stop sign or traffic light.
  - iv) Within 15 meters of a corner.
  - v) Where competitors following the proper route will enter the control from the opposite direction. This applies to On Route as well as Off Route Controls.
  - vi) Route controls should not be sited in close proximity to the next Time Control unless competitors are given adequate time and distance to complete the remaining route to the TC without incurring penalty.
- c) All controls must be identified by a marker board at least two 0.6 meters square in size. The background must be of a color contrasting with the surroundings and the identification marks. Identification marks must be provided so that a competitor may differentiate between a Time Control and a Route Control from a distance of not less than 0.10 of a kilometer. Identification marks shall be the letters TC or a clock face, indicating a Time Control and RC indicating a Route Control.
- d) The control marker shall be on the left side of the road, securely erected, close to the shoulder and clearly visible from the route. The marker shall be located not less than 12 meters from the location of the control except in the case of a non-stop Section when the marker shall be aligned with the marshal and shall form the exact location of the control. In the case of former, the marker shall form the boundary of the control which shall extend for a similar distance on the far side.

### **3.7.3 Control Procedure**

- a) Controls must open a minimum of 15 minutes before their standard time and must close after the maximum lateness authorized for the last car (i.e. last car plus thirty (30) minutes). A control may be authorized by the control closing car to close at a time earlier only if all cars still competing have passed that control.

- b) Control opening and closing times can be changed once a Section has started on the authority of a Senior Official (Opening and Closing Marshal, Clerk of the Course, Organizers and Stewards).
- c) Competitors arriving at a control shall align themselves directly in line with the official marker for the control in such a manner as not to impede the flow of traffic.
- d) If two (2) or more competitors arrive at the control at the same time, they shall align themselves one behind the other in the same sequence of their arrival. Doubling up or parallel parking is strictly prohibited.
- e) Any competitor overshooting a time control will be timed as he passed the control. He must leave his car where he stops and walk back to receive his time. Reversing into a control is prohibited.
- f) Competitors must clear all controls immediately upon receiving his time or control card.
- g) Competitors not respecting the control procedures may be subject to an Incorrect Control Procedure (ICP) penalty. If a penalty for ICP is assessed, a notation "ICP" must be made on the competitor's sheet and marshal's sheet. The notation "ICP" shall only be made after due warning by the marshal in the case of (d) and is subject to protest.
- h) The penalty for Incorrect Control Procedure shall be 50 points in navigational rallies and 60 seconds on a special stage.
- i) In the case of a Non-Stop Section, a competitor observed delaying within sight of a control cannot be given an ICP penalty. If, however, a competitor is observed to have obviously stopped within sight of a Time Control and before passing the Time Control board (except in the interest of safety), the marshal shall record as his Time-in, that time at which he was first observed to have stopped and shall note the word "stopped" on both the competitor's sheet and the marshal's sheet. However, marshals are expected to penalize flagrant violations and not minor hesitations which might occur when a competitor is attempting to continue to move forward.
- j) If a competitor is observed to execute a U-turn or attempting to reverse or is seen circling within sight of a Time Control, the control official shall give him the time when the maneuver was performed and will note the maneuver performed on the competitor's sheet as well as the marshal's sheet.
- k) In Stages Rallies no servicing will be allowed within 500 meters of time controls unless stated in the ASR's. The areas between TCs and special stage starts and between adjacent special stages not separated by a TC shall be a "No Service Area". Only the changing of a wheel(s) carried in the competing car, due to a puncture or damage, and the cleaning of lights, numbers or windshield, and other minor adjustments shall be permitted. These servicing allowances must be carried out by the competing crew only; no outside help shall be permitted.

### 3.7.4 Wrong Direction/Approach

- a) Wrong direction/approach occurs when a competitor arrives at a control marker from an approach other than that prescribed in the route instructions.
- b) If a competitor is observed to have initially made the correct approach, makes an error and immediately corrects this error completely beyond the jurisdiction and sight of the control, the wrong direction penalty will not be applied
- c) The following diagram shows a control with four (4) possible approaches. Those marked with an "X" shall constitute Wrong Direction/Approach:

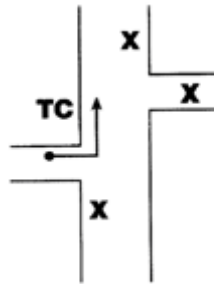

- d) If a penalty is to be assessed for wrong direction/approach, a notation "X" must be made on the competitor's sheet and marshal's sheet by the marshal at the control at the time the infraction occurs.
- e) U-turns, circling and weaving within sight of the Time Controls are not permitted and will be assessed a penalty equal to ICP (refer to Article 3.7.3 h). No warning shall be given and must be noted on both sides of the competitor's and marshal's sheet.
- f) Official overall mileage, official standard time (Car 0 Time) for the control and the next instruction number must be available at Time Controls.
- g) A California Time Control is such that a competitor must pick up a different route within sight of control.

## 3.8 Timing

### 3.8.1 Time Regulations

- a) The following shall be considered to apply to all rallies held under these Regulations:
  - i) **Standard Time** is the time of day a competitor number 0 is required to be at any specified point.
  - ii) **Scheduled Time** is the time of day each competitor is required to be at any specified point.

- Scheduled time for any competitor equals Standard Time plus the competitor's rally number multiplied by the time interval between competitors, unless otherwise specified in the ASR's.
- iii) **Target Time** is the period of time allowed to each competitor to travel the distance between any two (2) points.
  - iv) For the purpose of standardization, the interval between competitors shall be one (1) minute unless otherwise specified in the ASR's.
- b) The master clock and all official watches for the event shall be synchronized as close as possible to the rally start.
  - c) Timepieces to be used by the rally officials shall be:
    - i) Accurate and legible. Digital watches should be used at all times;
    - ii) Checked by an official as close to the start as possible. The time of checking shall be noted on the control sheet;
    - iii) Checked by an official as close to the finish of the event as possible. The time of checking shall be noted on the control sheet.
  - d) There shall be at least two (2) marshals at all controls where a time is to be recorded.
  - e) The following is standard timing procedure to be used on all rallies organized under these Regulations:
    - i) At all time controls, the marshal shall note on his record sheet and the competitor's sheet, the hour, minutes and 10ths of a second at which the competitor's vehicle stops in front of the control (not to be mistaken to read "control marker"). In rallies timed to the complete minute, the 10ths shall not be recorded.
    - ii) If the rally is to be scored to the nearest preceding whole minute, the control shall be located at the .00 mark of the minute.
    - iii) If the rally is to be scored to the nearest whole minute, the no penalty period shall be from 0.00 to 0.59 seconds of the correct minute.
    - iv) In the case of a Non-Stop section, if the competitor was observed to have flagrantly stopped before passing the time control marker (except in the interest of safety), the marshal shall record his time-in as the time at which he was first observed to have stopped (refer to Article 3.7.3).
    - v) A competitor's time-in will also be his time-out unless the ASR's specify otherwise.
    - vi) There shall be no timing or time allowances at route controls unless specifically stated in the ASRs and or route instructions.
    - vii) Errors by the marshal in recording the competitor's time will be corrected in scoring.
  - f) The maximum earliness permitted in a rally shall be 15 minutes and the maximum lateness permitted in a rally shall be 30 minutes except that this

- maximum lateness may be extended to 60 minutes at a rest halt or meal stop, if so specified in the ASRs.
- g) The maximum lateness at a finish control shall be 60 minutes i.e. to qualify as a finisher. However, for the purpose of scoring, a competitor who is more than 30 minutes late will receive the maximum penalty of 300 points.
  - h) A competitor's total lateness or earliness is defined as the difference between his scheduled time and his actual time.
  - i) If a competitor's total lateness or earliness at a time control exceeds the maximum earliness or lateness permitted, he shall be scored as having missed that control. Maximum lateness does not apply at a route control.
  - j) Maximum lateness or earliness may not be changed once a rally has started.
  - k) The rally will be run on the on the target time system and all earliness and lateness within the maximum must be maintained unless otherwise specified in the ASRs.
  - l) Pauses such as meal and rest stops, shall be used to reduce earliness and lateness unless otherwise specified.
  - m) Marshals shall not attempt to determine whether a competitor is within maximum earliness or lateness, but shall limit themselves to issuing and recording times for each competitor who checks in.
  - n) If a competitor believes that a marshal has misread his watch, he shall ask the marshal to re-check the time.
  - o) If the marshal agrees that he did misread his watch, he shall correct the time-in on the competitor's card and note the corrected time on his record sheet.
  - p) If the marshal does not agree that he misread his watch, the competitor shall base his calculations on the time-in recorded.
  - q) If a competitor doubts the accuracy of a marshal's watch, he shall ask the marshal to note in the comments column on his record sheet the time-in which the competitor believes to be correct. The marshal shall do so but shall not alter the time recorded on the competitor's card. The competitor shall base his calculations on the time recorded on his card.
  - r) At the end of the rally, the competitor shall submit a protest. If, as a result the accuracy of the marshal's watch and/or location is determined to be inaccurate, an allowance equal to the number of minutes shall be made to all competitors.
  - s) Rallies shall be scored on the "Target Time" or control to consecutive control principle, i.e. penalties incurred at a control shall be treated individually and no penalties thereby incurred shall be carried forward, unless otherwise specified in the ASRs. Nevertheless, a competitor will be deemed not to have reported at a control if he exceeds the maximum earliness or lateness.

- t) Any competitor who is early or late is required to reduce such earliness or lateness by either reducing or foregoing any period of time provided for remaining at meal or rest stops, unless otherwise specified in the ASRs.
- u) A competitor missing one or more consecutive time controls shall be deemed to be penalty free at the next control reached, provided he reaches within maximum earliness or lateness.
- v) If a competitor checks in to the same control more than once, the first visit shall be the time and approach recorded for the purpose of scoring.
- w) If a time control is improperly located, competitors shall be scored according to its actual location (See Article 3.8.1 r).
- x) A competitor who has been unduly delayed upon arrival or departure from a control, test or halt (i.e. TC, RC, gas or meal stop, special stage), due to an administrative error or tardiness on the part of the organizers or attending marshal, may ask for delay allowance of a specific time to be noted on the relative or following marshal's sheet and his own time card, accompanied by the marshal's signature. However, the competitor must maintain target time to the next TC, unless this delay has caused him to exceed his maximum lateness. A protest must be filed concerning the delay within the time allowed at the end of the rally. The acceptance or modification of this delay allowance is subject to the discretion of the stewards of the event.
- y) The marshal shall record sufficient information to identify every competitor who checks in.

### **3.9 Scoring and Results**

#### **3.9.1 Scoring**

- a) Competitors will start with 0 penalty points. The competitor incurring the least penalties will be the winner, and so on.
- b) A competitor's performance will be scored as follows, unless the penalties listed below are modified by the ASR's. However, such modifications are not permitted for Championship Rallies without specific authority of the CSC.
  - i) Missing a time control 300 Points
  - ii) Missing a route control 300 Points  
(N.B. A stop sign check will be considered a route control).
  - iii) Arriving at a time control before time due, where scoring is to be the full preceding minute - per minute. 20 Points
  - iv) Arriving at a time control after due time due, where scoring is to be the full preceding minute - per minute. 10 Points
  - v) Incorrect Control Procedure (see Article 3.7.3). 50 Points



- vi) Coming to an obvious stop within sight of a time control in a non-stop leg. 150 Points
- vii) Wrong direction/approach (see Article 3.7.4). 150 Points
- viii) Not attempting or being ready to attempt a test when instructed to do so. 300 Points
- ix) Not completing a test (see \* below). 150 Points
- x) Not performing a test correctly) see \* below). 150 Points
- xi) Making a false start in a test (see \* below). 150 Points
- xii) Breach of the Road Traffic Law or any statutory requirement as to the driving of a motor vehicle, or the construction, use and lighting of vehicles (see \* below). 300 Points
- xiii) Excessive noise or damage to exhaust system. 150 Points
- xiv) Damage to car. 150 Points
- xv) Visiting controls in the incorrect sequence. 150 Points
- xvi) For visiting a route control not on the correct route (i.e. an off route check). 150 Points
- xvii) Covering the distance between any two controls on a public roadway in less than  $\frac{3}{4}$  of the time allowed by the official times, when controls are more than 6 kilometers apart (see \* below). 300 Points
- xviii) Not complying with Parc Ferme. Exclusion
- xix) Failure to comply with any requirement of the ASR's, Road Book, Time Card or Special Test instructions for which no other penalty is applied. 300 Points
- xx) Penalties for Special Tests, (time taken in excess of that recorded for the fastest car in class who shall be penalty free) 1 Point per/sec up to a maximum of 100 Points
- \* The maximum penalty for a test shall not exceed 300 points under any circumstances. A test includes special stages and dexterities.
- \*\* Any combination of two (2) or more offences of this nature shall result in exclusion.
- xxi) Solely for establishing class positions on speed tests, the following penalty will apply. For failure to record a start or finish time in a test slowest recorded time in class plus 200 seconds.
- xxii) To be classified as a finisher, a competitor must report to the final control within a stipulated time and at least 50% plus one (1) of the time controls and route controls included in the scoring, unless otherwise specified in the ASR's.

### 3.9.2 Assessment of Performance

- a) Final overall and class positions will be determined by the aggregate of the total elapsed time taken on the special stages and tests, in addition to any road or other penalties assessed.

- b) The following penalties shall be added to the elapsed stages times:
- i) For each minute late at a TC - 10 seconds, up to a maximum of 300 seconds
  - ii) For each minute early at a TC - 20 seconds, up to a maximum of 300 seconds.
  - iii) For arrival in a control area from the direction of the subsequent stage - Exclusion.
  - iv) For not reporting to a TC within maximum earliness or lateness - Exclusion.
  - v) For starting but not finishing any stage or test - Exclusion.
  - vi) For not starting any special stage or test within maximum earliness or lateness - Exclusion.
  - vii) For not completing a test correctly, or taking the wrong route on a stage - Bogey time.
  - viii) Traversing any part of a stage in the opposite direction to rally traffic will result in exclusion from the event.
  - ix) For making a false start before 00 second of a minute - elapsed time plus 60 seconds.
  - x) For not being ready to start special stage or leg is the sequence given on the timecard - prescribed start time with the clock running.
  - xi) For not being ready to start any section or leg at time due - 60 seconds.
  - xii) For not complying with any reasonable instruction by an official provided a warning is given that a penalty will be applied - 60 seconds.
  - xiii) For abusing a Marshal – 60 seconds. (Each occurrence).
  - xiv) For any instance where a competitor has been proven to have unreasonably baulked another competitor – 60 seconds. Any consistent baulking will result in exclusion from the rally.
  - xv) For reversing into a stop control from the wrong direction or stopping within the declaration area between the flying finish and stop control. – Bogey time 1<sup>st</sup> occurrence. Any further infringement will result in exclusion.
  - xvi) Actual time taken for a stage will be the time used.
  - xvii) For any competitor who causes or is part of a serious blockage on a special stage, whether intentional or otherwise, if his actions prevent any other competitors from completing the stage competitively – Bogey time.
  - xviii) For servicing in a no service area – 10 minutes for the 1<sup>st</sup> occurrence. Any further infringement will result in exclusion.

### 3.9.3 Results

- a) Provisional scores for all competitors shall be posted at one time. Scores shall be posted on the Official Notice Board not less than one (1) hour and not more than three (3) days after the arrival time of the last possible finisher. The Official Notice Board must be located at the finish of the rally or some other designated place which shall be easily accessible to all competitors and specified in the ASRs.
- b) Corrections made to the scoring after protests have been considered, will be contained in the provisional results.
- c) When the protest proceedings have finished the results are final if:
  - i) The provisional scores were posted within the limits allowed.
  - ii) No protest decision has been deferred.
  - iii) No appeals have been submitted.
- d) If an Appeal Board hearing is held under the guidelines laid down in these Regulations, and the results are modified, the revised final results must be issued containing:
  - i) The Appeal Board's decision on all appeals heard.
  - ii) A complete set of scores (control by control) modified according to the decision of the protest(s).
- e) Results shall be sent to the Chairman of the CSC, the Championship Scorer(s) and the P.R. Officer as soon as they become official.
- f) All results must contain the following minimum information:
  - i) Name of the Rally;
  - ii) Name of the Organizers;
  - iii) Date of the rally;
  - iv) Names of Stewards;
  - v) Name of the Clerk of the Course;
  - vi) Name of the Secretary of the Event;
  - vii) Name of the Technical Inspector(s);
  - viii) Name of the Route Checker(s);
  - ix) Names of all Marshals employed who are JMMC members and number of controls manned by each;
  - x) Status of Rally (if any);
  - xi) Finishing positions listed in order (provisional or final);
  - xii) Make and model of vehicles;
  - xiii) Competitor's numbers;
  - xiv) Names of crew members;
  - xv) \*\*Official mileage and standard time of all time controls;
  - xvi) \*\*Penalty points incurred at each control by each competitor;
  - xvii) Total number of penalty points incurred by each competitor.

\*\* Refers to individual score sheets only

- g) Competitors having equal number of penalty points shall be considered tied. Subsequent positions shall be enumerated according to the number

- of vehicles listed ahead. If a tie breaker is to be applied, other than the ones described in this Regulation, it must be specified in the ASRs.
- h) In the case of Championship Rallies, equal positions and Championship points will be awarded. A tie breaker will be applied unless specified in the ASRs, for the purpose of distributing awards.
  - i) If a tie breaker is applied the following method shall be used:
    - i) Smallest number of crew;
    - ii) Furthest cleanest on road section from start;
    - iii) Furthest cleanest on road section from finish;
    - iv) Smallest capacity cc. rating;
    - v) Toss of a coin.
  - j) In the event of a tie on overall speed sections, the following tiebreakers shall be used:
    - i) Most entrants in class
    - ii) Cleanest from start
    - iii) Cleanest from finish
    - iv) Lower classed vehicle
    - v) Toss of a coin
  - k) In the event of a tie for overall on Stage Rallies the following tiebreakers shall be used:
    - i) Crew of car in lower class
    - ii) Crew of car that is faster on a greater number of stages.
    - iii) Crew with the least personalities
    - iv) Toss of a coin.

#### **3.9.4 Protest Time Limits**

In addition to the time Limits stated under Article 2.6.5 the following shall apply for Rallies:

- a) Any protest by a competitor concerning the accuracy of a marshal's watch or control location, must be submitted within 30 minutes of the competitor's Time-In at the finish of each Section.
- b) Any protest by a competitor concerning a delay allowance request must be submitted within 30 minutes of the competitor's Time-In at the finish of each Section.
- c) Any protest from a competitor concerning a mistake or irregularity occurring during the rally or which became evident during the rally, must be submitted within 30 minutes of the competitor's Time-In at the finish of each Section.
- d) Any protest from a competitor concerning the calculation of a score must be submitted within two (2) hours of the posting of Provisional Results at the designate location and time.

- e) The Steward may grant an extension to a competitor's allowable time to submit a protest in order to make it physically possible for the competitor to submit the protest.
- f) If the scores are not posted as per the ASR's, a competitor who believes that an error has been made in the calculations of a score, may submit a protest concerning the error to the Chief Steward (accompanied by the appropriate fee) within 24 hours of the scores being disclosed.
- g) If the Stewards decision on a protest considered at the finish of the rally is deferred (as in Article 1.5.8 c) a competitor or entrant, who believes that an error has been made in the revision of a score as a result of the deferred decision, may enter a protest concerning the error within 24 hours of the deferred decision.

### 3.9.5 Points and Awards

- a) Only JMMC members shall qualify for points, regardless of the status of the event. Awards shall be given to members of affiliated clubs and invited guests in the same manner as JMMC members.
- b) Awards shall be presented as follows:
  - i) 1 to 3 cars in class - 1<sup>st</sup> place only
  - ii) 4 to 6 cars in class - 1<sup>st</sup> & 2<sup>nd</sup> place only
  - iii) 7+ cars in class - 1<sup>st</sup>, 2<sup>nd</sup> & 3<sup>rd</sup> place
  - iv) Fastest overall - 1<sup>st</sup>, 2<sup>nd</sup> & 3<sup>rd</sup> place
  - v) Fastest 2WD - 1<sup>st</sup>, 2<sup>nd</sup> & 3<sup>rd</sup> place
 Additional awards may be specified in the ASRs.
- c) JMMC Class Points Schedule:

<u>Placing</u>	<u>3 Cars</u>	<u>4 - 6 Cars</u>	<u>7+ Cars</u>
1 <sup>st</sup>	110	130	150
2 <sup>nd</sup>	70	100	110
3 <sup>rd</sup>	<b>50</b>	80	90
4 <sup>th</sup>		70	80
5 <sup>th</sup>		60	70
6 <sup>th</sup>		<b>50</b>	60
<b>7<sup>th</sup></b>			<b>50</b>
<b>8<sup>th</sup></b>			<b>40</b>
<b>9<sup>th</sup></b>			<b>30</b>
<b>10<sup>th</sup> +</b>			<b>20</b>

#### d) Points Schedule For Major Rallies

- (i) **Competitors:**  
Total Distance ( Km)

<u>Placing</u>	<u>100 - 150</u>	<u>151 - 350</u>	<u>351 - 500</u>	<u>501 - 750</u>	<u>751+</u>
1 <sup>st</sup>	300	350	410	500	600
2 <sup>nd</sup>	260	300	350	410	480
3 <sup>rd</sup>	230	260	300	350	410
4 <sup>th</sup>	210	230	260	300	350
5 <sup>th</sup>	200	210	230	260	300
6 <sup>th</sup>	190	200	210	230	260
7 <sup>th</sup>	185	190	200	210	230
8 <sup>th</sup>	180	185	190	200	210
9 <sup>th</sup>	175	180	185	190	200
10 <sup>th</sup>	170	175	180	185	190
11 <sup>th</sup>	165	170	175	180	185
12 <sup>th</sup>	160	165	170	175	180
13 <sup>th</sup>	155	160	165	170	175
14 <sup>th</sup>	150	155	160	165	170
15 <sup>th</sup>	145	150	155	160	165
16 <sup>th</sup>	140	145	150	155	160
17 <sup>th</sup>	135	140	145	150	155
18 <sup>th</sup>	130	135	140	145	150
19 <sup>th</sup>	125	130	135	140	145
20 <sup>th</sup>	120	125	130	135	140
21 <sup>st</sup> to last finisher	110	115	120	125	130

Points above apply to each member of a 2 man crew - for 3 man crews less 10%.

e) **Points Schedule for Stages rally Championships**

	Overall Points
1 <sup>st</sup> place	10
2 <sup>nd</sup> place	8
3 <sup>rd</sup> place	6
4 <sup>th</sup> place	5
5 <sup>th</sup> place	4
6 <sup>th</sup> place	3
7 <sup>th</sup> place	2
8 <sup>th</sup> place	1

**3.10 Officials**

**3.10.1 Duty of Officials**

- a) In addition to the duties of the officials, stipulated in Article 2.5, the additional duties in this Regulation shall apply to rally events.

### **3.10.2 The Chief Steward**

The Chief Steward shall be responsible for seeing that the route is checked by an appointed route checker prior to the rally using a set of typed instructions, at the time of day and under the same conditions as anticipated for the event itself.

The purposes of this check are:

- a) To ensure that the route and instructions comply with these Regulations the ASR's of the rally and the character of the event as specified by the Managing Committee.
- b) To check the suitability of the start, finish, gas, meal and rest stop facilities.
- c) To find and eliminate any ambiguities or incorrect instructions mileage errors etc.
- d) To check the location of controls to ensure that Article 3.7.2 has been complied with, particularly with regard to safety.
- e) To verify that timing calculations are correct and that controls are at 00 mark of the minute unless scored to the 10<sup>th</sup> of a minute.
- f) To verify that specified speeds are safe and conform to regulations with particular attention to populated areas and heavily traveled main roads.

### **3.10.3 The Clerk of the Course**

The Clerk of the Course shall:

- a) Be responsible for the selection of the route, scheduling siting of control points and all other matters pertaining to the running of the event itself.
- b) Take reasonable precautions to avoid inconvenience being caused to the general public or local residents.
- c) Satisfy himself that all officials are at their posts and report the absence of any of them to the stewards of the event.
- d) Satisfy himself that all officials are provided with the necessary information to enable them to properly carry out their duties.
- e) Satisfy himself that each competitor carries the proper identification required for the event.
- f) Make arrangements so that competitors shall start in the right order and at the proper time.
- g) Make arrangements for the collection of all records that may be necessary for the determination of the results and to ensure that they are delivered to the official responsible for scoring the event.

- h) Satisfy himself that any average speeds required by the instructions, while the competitors are on the public roads, shall not require or induce the drivers to exceed any statutory limits, or be at a speed which might be considered dangerous or unreasonable.
- i) Satisfy himself that a course opening car traverses the entire rally route prior to the event in accordance with Article 3.11.1 d.
- j) Be responsible for recruiting and if necessary, training sufficient marshals for the proper and efficient functioning of all manned controls. He shall satisfy himself that all marshals are properly stationed during the entire period that their respective controls are to be opened and he shall also assure himself that they have all the information, documents and equipment that might be required in the fulfillment of their duties.

#### **3.10.4 The Secretary of the Event**

The Secretary of the Event shall be responsible for all documents pertaining to the organization of the event and all announcements required in connection therewith. In particular he shall:

- a) Satisfy himself that all entrants have submitted properly completed entry forms.
- b) Satisfy himself that all documents required from competitors are in order i.e. valid drivers licenses, etc.
- c) Satisfy himself that all Officials and Stewards are provided with any forms or documents that may be required for the proper performance of their functions.
- d) Be responsible, together with the Chief Scorer, for the prompt notification, in writing, of the event to all competitors in accordance with Article 3.9 of these regulations.

#### **3.10.5 The Chief Scorer**

The Chief Scorer shall be responsible for all timekeeping and scoring arrangements for the event, including any assistance he may require, in conjunction with the Secretary of the event, be responsible for the dissemination of results in accordance with Article 3.9 of these regulations.

### **3.11 Conducting a Rally**

#### **3.11.1 Administration of The Rally**

- a) Instructions, including timing calculations and control locations must be checked by someone other than the writer so that ambiguous instructions and errors may be found and corrected. Reproduced instructions must be carefully proofread against the original copy to ensure that typographical



- errors have not been committed. Preferably, the check ride should be made from a set of final instructions which must be typed in such a fashion that they are easily read. Rallies must be planned far enough in advance to permit the Organizers and Stewards to ensure that the final instructions are checked.
- b) A draw for starting position must be held. The draw shall include all entries received by the organizers until the limit is met. Entries in excess of the limit shall be placed on a standby list in order of their receipt.
  - c) Competitors shall start each section of a rally at intervals of not less than one (1) minute apart.
  - d) A course opening car must be used to ensure that the entire route is passable and to provide alternate routes around the blockage(s). This vehicle must cover the route not less than 15 minutes or more than 1 hour before the rally. If the route becomes blocked after the course opening car, it shall be deemed to be "force majeure" and no allowance shall be made. If a portion of the route is not passable and it can be proven that a course opening car did not travel that portion of the route within the time limits stipulated, due allowances, must be made in scoring up to and including the end of the section so that the competitor is not penalized because of the route blockage.
  - e) In the absence of a control opening car, the course opening car shall ensure that all controls are correctly located and that control time pieces are correctly set (See Article 3.8.1 item c ii). If the control or the course opening car finds a control missing, that official shall post an "Unmanned" sign at a point where it shall be clearly visible to all competitors.
  - f) Where possible, a control closing car must be used to ensure that they do not close too soon, to check control time pieces (see Article 3.8.1 item c ii), and collect the control record sheets and bring them to the finish, or deliver them to the chief scorer.
  - g) If the control opening and/or closing cars are unable to complete the route for some unforeseen reason, this shall not of itself be reason for elimination of controls from scoring.
  - h) A registration must be held at the start of an event during which a register must check that all competitors possess valid documents as listed under Article 3.1.2 item d of these Regulations.
  - i) An inspection must be held at the start of the event during which the Technical Inspector shall check all competing vehicles as described in Article 3.1.3 item c. The Technical Inspector must also make note of the license number of each competing vehicle described on the entry form.
  - j) The organizers, stewards and any other authorized persons must be identified and introduced at the Drivers Meeting.
  - k) Adequate instructions, including time and location must be provided to service crews on major rallies. These instructions should be no more than 80 kilometers apart and will include any gas halts, meal stops, rest halts,

etc. Any other locations given must be the same as pick-up points given to competitors so as not to compromise the route of the rally.

### **3.11.2 Official Notices**

- a) All official notices must be signed by the Clerk of the Course, or the opening Marshal.
- b) Any known corrections to the route instructions must be prominently posted at the start of the section to which they apply.
- c) If a change of the route instructions become necessary after a leg has started, an official notice containing changes to the route and/or timing must be prominently posted at a control or on a clearly visible and securely placed sign. Such a notice must be placed before the maximum earliness of the first car to pass that point.
- d) Any official notice making changes to the ASR's must be posted before the start of the section to which they apply and must be signed by the Chief Steward.
- e) A timing sheet stating the official mileage of all controls and the correct elapsed times to all timed controls must be posted at the finish before the due time of the first car.



# JAMAICA MILLENNIUM MOTORING CLUB

## Section 4

### Sprints

#### Table of Contents

#### Section 4 Sprints

##### **4.1 The Sprint Regulations**

- 4.1.1 General Principle
- 4.1.2 Conducting the Event
- 4.1.3 The Championship Round
- 4.1.4 Penalties
- 4.1.5 Re-Runs
- 4.1.6 Abandonment
- 4.1.7 Technical Inspection
- 4.1.8 Points and Awards
- 4.1.9 Protest Time Limits

##### **4.1 The Sprint Regulations**

The Sprint Regulations is a part of the JMMC Motor Sports Rules and Regulations.

##### **4.1.1 General Principle**

- a) The Sprint Regulations shall apply to all Sprint events (Hillclimb and Autocross, etc.). The Sprint Regulations are intended to provide a uniform method of handling events to ensure the safety of entrants and spectators. The Sprint Regulations contained herein, in conjunction with the JMMC Motor Sport Rules and Regulations, shall apply to all Sprint Events sanctioned by the Jamaica Millennium Motoring Club. **Guidelines**

**for Organizers of Sprint events can be found in Section 2 of the General Regulations of the JMMC.**

#### 4.1.2 Conducting the Event

- a) Each course shall be clearly demarcated by the use of flags, cones, "no-entry" tape, rope or any other suitable means.
- b) **Entry requirements shall be specified in the ASR's.** Drivers may enter in only one class, and may drive only one car in that class. **For clarity: Only D.O.T or TUV approved tyres may be used.**
- c) Cars may not be entered in more than one class and may not be driven by more than two (2) nominated drivers.
- d) Cars must be entered and competed in the class for which they qualify.
- e) Where entries are limited, selection will be made in the following manner:
  - i) Single entry cars - Driver A.
  - ii) Double entry cars - Driver B as per date and time entry is received.
  - iii) Standby drivers will be notified after the close of entries and the following action taken:
    - 1. Once the driver accepts the standby entry, he / she is required to be present with his/her car for Technical Inspection at the specified time. However, if a space does not become available, the entry fee is refundable.
    - 2. If a driver accepts the standby entry and does not arrive for Technical Inspection, etc., the Entry Fee is not refundable.
- f) All entrants must complete and sign entry forms and waivers, and pay the prescribed entry fee, before being allowed to take part in the event.
- g) **No changes in driver or vehicle will be permitted after the start of the event. Any changes after entries have closed must be approved by the Stewards.**
- h) A convoy run comprised of entered drivers only, should be conducted by the Organizer and / or the Clerk of the Course, and will traverse the entire route at a sedate pace.
- i) Any competitor who is not able to take part in the convoy run for any reason will forfeit that run.
- j) To facilitate the expeditious running of the event, competitors asked to standby for the start of their timed run are expected to position their cars in safe proximity to the start line and be ready to promptly take their position when requested by the starter. Failure or tardiness in complying with these instructions may result in the denial of his / her timed run and is not subject to protest.
- k) Any competitor unable or unwilling to take their assigned place in the running order may forfeit that particular run, and this is not subject to protest.

- l) Any competitor who ignores or refuses to accept any ruling, decision, or reasonable request of the officials of the meet, may be excluded from such event and be subject to further disciplinary action.
- m) There shall normally be three (3) qualifying or timed runs followed by a Championship round of an increased length whenever this is possible or desirable, for the top 10 qualifiers. This shall be specified in the ASRs.
- n) **In addition to any electronic timing system**, a minimum of two (2) Time Keepers shall be used **per competitor**.
- o) At least two (2) Judges of Fact shall be appointed to spot infringements. A Judge of Fact shall be situated at the start / finish and another shall be situated on the other side of the test circuit. If the start and finish are in separate locations, at least three (3) Judges of Fact are required (one of whom may be the Starter).
- p) Two (2) flags shall be provided to each of the Judges of Fact. A red flag is to be shown when an infraction is made and a black flag when the route is not completed satisfactorily. Decisions made by these officials are final and are not subject to protest.
- q) **The organizer and appointed officials may not actively compete in these events.**
- r) The fastest time recorded on the competitors' three (3) qualifying runs shall be applied towards class and overall positions and awards (see Article 4.1.8). Points thus gained will be applied towards various Championships (see Article 4.1.8).
- s) In the event of time constraints, inclement weather etc., the Chief Steward may reduce the number of qualifying runs.

#### **4.1.3 The Championship Round**

- a) For Championship Rounds, the ten (10) fastest competitors who are JMMC members shall qualify. Non JMMC members who qualify in the top ten (10) may run at the discretion of the Organizer and receive an award. However, no points will be awarded to them and they must not reduce the number of JMMC members who qualify.
- b) Whenever a JMMC member who qualifies elects no to, or is unable to take part in the Championship Round, the next fastest JMMC member will substitute, and so on, until all the available slots are filled.

#### **4.1.4 Penalties**

Infringement of the boundary markers will attract the following penalties:

- a) Setting off ahead of the Starter (False Start)      5 seconds.
- b) Infringement of boundary markers                      2 seconds per marker.
- c) For not completing the course                              No Time (DNF).

## **Re-Runs**

No re-runs shall be permitted except in the case of a timing failure or when an obvious obstruction on the track prevents the normal running of the event. This determination shall be made by the Chief Steward of the event, and shall be final.

### **4.1.5 Abandonment**

- a) If an event is abandoned the following shall apply:
  - i) If at least one (1) complete round has been run, class points and awards will be given.
  - ii) Top 10 positions and championship points will be determined by the 10 fastest times existing at the time of abandonment. All incomplete rounds shall be ignored.

### **4.1.6 Technical Inspection**

- a) All vehicles shall comply with the Mandatory Safety Requirements as specified in Section 6.1.1 of the JMMC Regulations.
- b) Mandatory Drivers equipment shall be presented at Technical Inspection.
- c) Technical Inspection will open two (2) hours prior to the scheduled start of the event and close 30 minutes prior to the scheduled start or at the time specified in the ASRs.
- d) No cars will be allowed to start unless they have successfully completed Technical Inspection.
- e) It is incumbent on competitors to ensure that their cars are presented to the Technical Inspector in sufficient time for them to complete their duties in the allotted time.
- f) Cars shall not be inspected after the scheduled close of the Technical Inspection, and this is not subject to the Organizers discretion.

### **4.1.7 Points and Awards**

- a) Only JMMC members shall qualify for points, regardless of the status of the event. Awards shall be given to members of affiliated clubs and invited guests in the same manner as JMMC members.
- b) Awards shall be presented as follows:
  - i) 1 to 3 cars in class - 1<sup>st</sup> place only.
  - ii) 4 to 6 cars in class - 1<sup>st</sup> & 2<sup>nd</sup> place only.
  - iii) 7+ cars in class - 1<sup>st</sup>, 2<sup>nd</sup> & 3<sup>rd</sup> place.
  - iv) Fastest overall - 1<sup>st</sup> place only.
  - v) Fastest 2WD - 1<sup>st</sup> place only.

vi) Championship Round - 1<sup>st</sup>, 2<sup>nd</sup> & 3<sup>rd</sup> place.

**Other awards may be presented but these must be detailed in the ASRs.**

c) JMMC Class Points Schedule:

<u>Placing</u>	<u>3 Cars</u>	<u>4 - 6 Cars</u>	<u>7+ Cars</u>
1 <sup>st</sup>	110	130	150
2 <sup>nd</sup>	70	100	110
3 <sup>rd</sup>	<b>50</b>	80	90
4 <sup>th</sup>		70	80
5 <sup>th</sup>		60	70
6 <sup>th</sup>		<b>50</b>	60
7 <sup>th</sup>			<b>50</b>
<b>8<sup>th</sup></b>			<b>40</b>
<b>9<sup>th</sup></b>			<b>30</b>
<b>10<sup>th</sup> +</b>			<b>20</b>

All Non-finishers are credited with 10 points

**For scoring purposes, a class entrant must record at least one (1) DNF in order to be counted amongst those that make up the class.**

d) JMMC Championship Round Points Schedule:

<u>Placing</u>	<u>Points</u>
1st	20
2nd	15
3rd	12
4th	10
5th	8
6th	6
7th	4
8th	3
9th	2
10th	1

**All Non-finishers are credited with 1/2 point.**

e) In the event of a tie, equal class or championship points will be awarded. However, for the purpose of presenting awards the sum of the times will be used as a tie breaker.

f) Cars falling in classes that have less than three (3) entries must compete on their own. Points thus awarded will be based on the three (3) car

- category, 2<sup>nd</sup> and 3<sup>rd</sup> place points only; e.g. if only two (2) cars 70 & 50 points, if only one (1) car 50 points.
- g) Sprint Championship: Eligibility
- i) The maximum number of points which can be accumulated will come from the total number of Sprint events held for the championship year.
  - ii) Points are awarded based on the results of the Championship Run on that event as per Article 4.1.8 d.
  - iii) The top ten 2WD cars overall in each sprint event, (not including the Championship Run) will earn points based on Article 4.1.8 c which will go towards the 2WD car sprint championship.
  - iv) In the event of a tie for championship position, the following criterion shall be used to break the tie in the order given:
    - 1. Most events entered.
    - 2. Most wins.
    - 3. Highest placing
    - 4. Share Championship

#### **4.1.8 Protest Time Limits**

In addition to the time limits stated under Article 2.6.5 the following shall apply for all Sprints:

- a) Any protest by a competitor concerning the accuracy of a marshal's watch must be submitted within 10 minutes of the competitor's Time-In at the finish of the run in question.
- b) Any protest from a competitor concerning a mistake or irregularity occurring during the event or which became evident during the event, must be submitted within 15 minutes of the finish of the event.
- c) Any protest from a competitor concerning the calculation of a time must be submitted within 15 minutes of the finish of the event.





# JAMAICA MILLENNIUM MOTORING CLUB

## Section 5

### Dexterity Tests

#### Table of Contents

#### Section 5 Dexterity Tests

##### **5.1 The Dexterity Regulations**

###### 5.1.1 General Principle

##### **5.2 Conducting the Event**

- 5.2.1 Entries
- 5.2.2 Officials
- 5.2.3 Classification
- 5.2.4 Points and Awards
- 5.2.5 The Course
- 5.2.6 The Championship Round
- 5.2.7 Timing
- 5.2.8 Penalties
- 5.2.9 Re-runs
- 5.2.10 Abandonment
- 5.2.11 Technical Inspection
- 5.2.12 Vehicle
- 5.2.13 Protest Time Limits

##### **5.1 The Dexterity Regulations**

The Dexterity Regulations is a part of the JMMC Motor Sports Rules and Regulations.

###### **5.1.1 General Principle**

The Dexterity Regulations shall apply to all Dexterity events. The Dexterity Regulations are intended to provide a uniform method of handling events and to ensure the safety of entrants and spectators. The Dexterity Regulations contained herein, in conjunction with the JMMC Motor Sports Rules and Regulations, shall apply to all Dexterity events sanctioned by the Jamaica Millennium Motoring Club. **Guidelines for Organizers of Dexterity events can be found in Section 2 of the General Regulations of the JMMC.**

## 5.2 Conducting the Event

### 5.2.1 Entries

- a) A competition driver's license is not a requirement.
- b) Entry requirements shall be specified in the ASR's.
- c) Drivers may enter in only one class, and may drive only one car in that class.
- d) Cars may not be entered in more than one class and may not be driven by more than two (2) nominated drivers.
- e) Cars must be entered and competed in the class for which they qualify.
- f) Where entries are limited, selection will be made in the following manner:
  - i) Single entry cars - Driver A.
  - ii) Double entry cars - Driver B as per date and time entry is received.
  - iii) Standby drivers will be notified after the close of entries and the following action taken:
    - 1. Once the driver accepts the standby entry, he / she is required to be present with his/her car for Technical Inspection at the specified time. However, if a space does not become available, the entry fee is refundable.
    - 2. If a driver accepts the standby entry and does not arrive for Technical Inspection, etc. the entry fee is not refundable.
- g) All entrants must complete and sign entry forms and waivers, and pay the prescribed entry fee, before being allowed to take part in the event.
- h) **No changes in driver or vehicle will be permitted after the start of the event. Any changes after entries have closed must be approved by the Stewards.**

### 5.2.2 Officials

- a) **In addition to any electronic timing system**, a minimum of two (2) Time Keepers shall be used **per competitor**.
- b) At least two (2) Judges of Fact shall be appointed to spot infringements. A Judge of Fact shall be situated at the start/finish and another shall be

situated on the other side of the test circuit. If the start and finish are in separate locations, at least three (3) Judges of Fact are required (one of whom may be the starter).

- c) Two (2) flags shall be provided to each of the Judges of Fact. A red flag is to be shown when an infraction is made and a black flag when the route is not completed satisfactorily. Decisions made by these officials are final and are not subject to protest.
- d) The organizer and appointed officials may not actively compete in these events.

### 5.2.3 Classification

- a) Cars will be separated into five (5) classes as follows:  
 Class 1 - Front Wheel Drive (FWD).  
 Class 2 - Front Wheel Drive with Limited Slip/lock Diff (FWD + LSD).  
 Class 3 - Rear Wheel Drive (RWD).  
 Class 4 - Rear Wheel Drive with Limited Slip/lock Diff (RWD + LSD).  
 Class 5 - All 4WD (continuous or other) (4WD).
- b) A Ladies Class will be recognized as long as there are three (3) or more such entries, without any further class demarcation and will attract all normal awards.

### 5.2.4 Points and Awards

- a) Only JMMC members shall qualify for points, regardless of the status of the event. Awards shall be given to members of affiliated clubs and invited guests in the same manner as JMMC members.
- b) Awards shall be presented as follows:
  - i) 1 to 3 cars in class - 1<sup>st</sup> place only.
  - ii) 4 to 6 cars in class - 1<sup>st</sup> & 2<sup>nd</sup> place only.
  - iii) 7+ cars in class - 1<sup>st</sup>, 2<sup>nd</sup> & 3<sup>rd</sup> place.
  - iv) Fastest overall - 1<sup>st</sup> place only.
  - v) Fastest 2WD - 1<sup>st</sup> place only.
  - vi) Championship Round - 1<sup>st</sup>, 2<sup>nd</sup> & 3<sup>rd</sup> place.

**Other awards may be presented but these must be detailed in the ASRs.**

- c) JMMC Class Points Schedule:

<u>Placing</u>	<u>3 Cars</u>	<u>4 - 6 Cars</u>	<u>7+ Cars</u>
1 <sup>st</sup>	110	130	150
2 <sup>nd</sup>	70	100	110
3 <sup>rd</sup>	<b>50</b>	80	90
4 <sup>th</sup>		70	80
5 <sup>th</sup>		60	70

6 <sup>th</sup>	50	60
7 <sup>th</sup>		50
8 <sup>th</sup>		40
9 <sup>th</sup>		30
10 <sup>th</sup> +		20

All Non-finishers are credited with 10 points

**For scoring purposes, a class entrant must record at least one (1) start attempt in order to be counted amongst those that make up the class.**

d) JMMC Championship Round Points Schedule:

<u>Placing</u>	<u>Points</u>
1 <sup>st</sup>	20
2 <sup>nd</sup>	15
3 <sup>rd</sup>	12
4 <sup>th</sup>	10
5 <sup>th</sup>	8
6 <sup>th</sup>	6
7 <sup>th</sup>	4
8 <sup>th</sup>	3
9 <sup>th</sup>	2
10 <sup>th</sup>	1

**All Non-finishers are credited with 1/2 point.**

- e) In the event of a tie, next fastest time shall be used and then the lower cc rating.
- f) Cars falling in classes that have less than three (3) entries must compete on their own. Points thus awarded will be based on the three (3) car category 2<sup>nd</sup> and 3<sup>rd</sup> place points only e.g. if only two (2) cars 70 & 50 points, if one (1) car 50 points only.
- g) Dexterity Championship: Eligibility
  - i) The maximum number of points will come from the total number of Dexterity events held for the championship year.
  - ii) Points are awarded based on the results of the Championship Run on that even as per 5.2.4 d.
  - iii) In the event of a tie for championship position, the following criterion shall be used to break the tie in the order given:
    1. Most events entered.
    2. Most wins.
    3. Highest placing.

#### 4. Share Championship.

##### 5.2.5 The Course

- a) Each course shall be clearly demarcated by the use of tyres, cones or any other suitable means.
- b) The course will be laid out in a manner which puts the emphasis on maneuverability, precision and car control, and not on speed. The course shall be laid out within the following specifications:
  - i) Cars must not be permitted to travel more than 50 yards between maneuvers.
  - ii) Such maneuvers must require a change of direction. Three (3) marker slaloms are the minimum requirement for this purpose.
  - iii) All lines or pairs of adjacent markers forming part of a test instruction must be a minimum of 20ft. and a maximum of 32 ft. long, measured in the direction of travel.
  - iv) Competitors must either stop astride a penalty line or make a change of direction of at least 90 degrees, no more than 25 yards before the finish line.
  - v) The size of any garages and boxes must have a minimum length of 15 ft. and a minimum width of 11 ft.
  - vi) Gates will be a minimum width of 10ft.
  - vii) Baulk lines should be clearly marked on the ground and extend the full length of the box and height of the cars.
- c) All course markers must have a penalty for striking or infringing them.
- d) The route to be followed by the competitors on the course must be made available to each driver beforehand.
- e) There shall be no optional direction of travel unless specifically stated in the ASR's.
- f) If the route of the tests is changed for each timed run, then the sum of each time taken in each round shall decide the class and overall positions. In this case, the penalty applied for not completing a test will be the slowest man in the class plus five (5) seconds (see Article 5.2.8 items e and g).
- g) The 4<sup>th</sup>, or Championship round, may be a previously used route or an entirely new route at the discretion of the organizer.

##### 5.2.6 The Championship Round

- a) For Championship Rounds, the ten (10) fastest competitors who are JMMC members shall qualify. Non JMMC members who qualify in the top ten (10) may run at the discretion of the Organizers and receive an award. However, no points will be awarded to them and they must not reduce the number of the JMMC members who qualify.

- b) Whenever a JMMC member who qualifies elects not to, or is unable to take part in the Championship Round, the next fastest JMMC member will substitute, and so on, until all available slots are filled.

### 5.2.7 Timing

- a) Cars will be started and timed singly (i.e. only one (1) car on the course at a time). **In cases where course design allows, two cars may be on course at a time but this is subject to approval of the Stewards and must be stated in the ASRs.**
- b) Timing will begin on the starter's signal and end on the Driver's signal from a stationary vehicle or as otherwise stated in the ASRs.
- c) The finish must have a baulk line placed at a minimum of 9ft. and a maximum of 15ft. after the finish line.
- d) There shall normally be four (4) timed runs. The 1<sup>st</sup> three (3) will count towards class points, the fastest of which will be the one (1) applied if the same route is used in all three (3) runs. The 4<sup>th</sup> run will be a slightly modified 3<sup>rd</sup> run and will be competed only by the ten (10) fastest car/driver combinations of the day.
- e) In the event of time constraints, inclement weather etc., the Chief Steward may reduce the number of timed runs.

### 5.2.8 Penalties

Penalties are as follows:

- a) Setting off ahead of the starter (False Start) - No Time (DNF).
- b) Infringement of baulk line by any part of the vehicle (bumper, fender, etc.) - 3 seconds.
- c) For not completely entering box or garage all four (4) wheels - 3 seconds.
- d) For infringing or striking any marker or line of route - 2 seconds per marker.
- e) For not completing a test - No Time (DNF).
- f) For doing a test incorrectly but doing all sequences in proper direction (i.e. when a mistake is properly corrected) - No Penalty.
- g) For doing any part of a test, course and or sequence incorrectly without applying rule (f) above, the run will be terminated by a Marshal's signal. Return to pit by a safe route. - No Time (DNF).
- h) For infringing or striking any marker forming part of the finishing box or garage - 10 Seconds.

### 5.2.9 Re-Runs

No re-runs shall be permitted except in the case of timing failure or an obvious obstruction on the circuit which precludes the normal running of the event. This determination will be made by the Chief Steward of the event, and shall be final.

#### **5.2.10 Abandonment**

If an event is abandoned the following shall apply:

- a) If at least one (1) complete round has been run, class points and awards will be given.
- b) Top ten (10) positions and championship points will be determined by the ten (10) fastest times existing at time of abandonment. All incomplete rounds shall be ignored.

#### **5.2.11 Technical Inspection**

- a) Technical Inspection will open two (2) hours prior to the scheduled start of the event and close thirty (30) minutes prior to the scheduled start or at the time specified in the ASR's.
- b) No cars will be allowed to start unless they have successfully passed Technical Inspection.
- c) It is incumbent on competitors to ensure that their cars are presented to the Technical Inspector in sufficient time for them to complete their duties in the allotted time.
- d) Cars shall not be inspected after the scheduled close of the Technical Inspection, and this is not subject to the organizers discretion.

#### **5.2.12 Vehicle**

- a) All vehicles that comply with the Mandatory Safety Requirements as specified in Section 6.1.1 of the JMMC Regulations shall be eligible to compete with the following exceptions:
  - i) A three (3) point seat belt for the driver is mandatory.
  - ii) Roll cages/bars are not required.
  - iii) A fire extinguisher is not required.
  - iv) A first aid kit is not required.
  - v) **D.O.T or TUV street-legal tyres with a wear rating of 200 or higher only.**

#### **5.2.13 Protest Time Limits**

**In addition to the time limits stated under Article 2.6.5 of the JMMC regulations the following shall apply for all Dexterities:**

- a) **Any protest by a competitor concerning the accuracy of a marshal's watch must be submitted within 10 minutes of the competitor's Time-In at the finish of the run in question.**
- b) **Any protest from a competitor concerning a mistake or irregularity occurring during the event or which became evident during the event, must be submitted within 15 minutes of the finish of the event.**
- c) **Any protest from a competitor concerning the calculation of a time must be submitted within 15 minutes of the finish of the event.**





# JAMAICA MILLENNIUM MOTORING CLUB

## Section 6

### Vehicle Requirements for Speed Events

#### Table of Contents

#### Section 6

#### Vehicle Requirements for Speed Events

##### 6.1 Technical Specifications

- 6.1.1 Mandatory Safety Requirements
- 6.1.2 Principles of Classification
- 6.1.3 Standard Production (JN)
- 6.1.4 Modified Production (JA)
- 6.1.5 Open Class (JC)
- 6.1.6 Vehicle Logbooks
- 6.1.7 Weighing of Vehicles
- 6.1.8 Protest against a Vehicle

#### Section 6

#### Vehicle Requirements for Speed Events

##### 6.1 Technical Specifications

##### 6.1.1 Mandatory Safety Requirements

- a) The responsibility to ensure that the vehicle and drivers equipment complies with these Regulations and is safe rests solely and at all times with the Entrant and Driver. The inspection of a vehicle is not a guarantee of the vehicles safety.
- b) The following safety items and standards shall be mandatory for all speed events and rallies with special stages:
  - i) Vehicles must be of sound construction and properly maintained in good mechanical condition.

- ii) Safety Belts, for all cars. **A safety harness must be used in its homologation configuration without any modifications or removal of parts, and in conformity with the manufacturer's instructions.** The required minimum is a five (5) point harness with three inch (3") lap for all occupants. **It is prohibited for the seat belts to be anchored to the seats or their supports. A safety harness may be installed on the anchorage points of the series car.** **The recommended geometrical locations of the anchorage points are shown in drawing N° 253-42.**

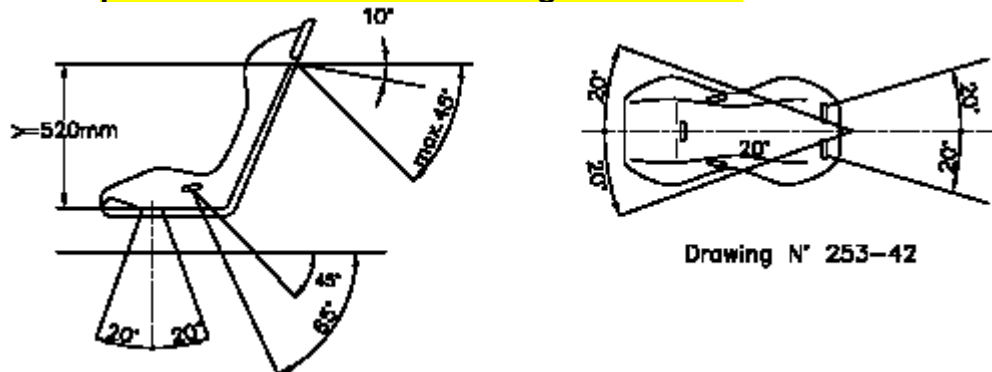

Drawing N° 253-42

**In the downwards direction, the shoulder straps must be directed towards the rear and must be installed in such a way that they do not make an angle of more than 45° to the horizontal from the upper rim of the backrest, although it is recommended that this angle should not exceed 10°. The maximum angles in relation to the centre-line of the seat are 20° divergent or convergent.**

**Anchorage points creating a higher angle to the horizontal must not be used unless the seat meets the requirements of the FIA standard.**

**In that case, the shoulder straps of 5-point safety harnesses may be installed on the rear seat lap strap anchorage points originally mounted by the car manufacturer.**

**A safety harness must not be installed on a seat having no head restraint or having a backrest with integrated head restraint (no opening between backrest and head restraint).**

**The lap and crotch straps should pass not over the sides of the seat but through the seat, in order to wrap and hold the pelvic region over the greatest possible surface.**

**The lap straps must fit tightly in the bend between the pelvic crest and the upper thigh. Under no conditions must they be worn over the region of the abdomen.**

Holes may be made in the series seat. Care must be taken that the straps cannot be damaged through chafing against sharp edges.

The shoulder straps may also be fixed to the safety roll-cage or to a reinforcement bar by means of a loop, and may also be fixed to the top anchorage points of the rear belts, or be fixed or leaning on a transversal reinforcement welded to the backstays of the roll-bar.

- iii) All cars must be fitted with a body of adequate strength and construction which will provide a compartment for the driver and passenger to be effectively isolated from the engine, gearbox, transmission, drive shafts, battery, road wheels and suspension.
- iv) Cars must have a protective bulkhead between the engine, gas tank(s), battery and the driver's/passenger's compartment, suitable and sufficient to prevent the passage of flame in the case of a fire. An exception will be made for vehicles fitted with a properly installed FIA approved fuel cell (FT3, **FT3.5 or FT5**) which contains fire protection inherent in its design. However, they will be subject to article 6.1.1 item v below.
- v) Vehicles fitted with fuel tanks not supplied as standard equipment by the manufacturers, must be vented to outside of the vehicle. The vent or vent hose shall have a one way check valve to stop the flow of fuel to the outside of the fuel tank. **It is authorized to equip a tank with ventilation exiting through the car roof. The position and the dimension of the filler hole as well as that of the cap may be changed as long as the new installation does not protrude beyond the bodywork and guarantees that no fuel shall leak into one of the interior compartments of the car. If the filler hole is situated inside the car, it must be separated from the cockpit by a liquid-tight protection.** FIA approved fuel cells (FT3, **FT3.5 or FT5**) are strongly recommended for all cars.
- vi) All articles or equipment which if left loose could present a hazard to the crew must be properly secured or removed prior to competition.
- vii) Roll cages (**also referred to as Safety Cages**) of approved specification, suitably padded to protect the head and limbs of all occupants with six (6) anchoring points **are required** for all cars.
  - a) **A roll cage is structural framework made up of a main roll-bar and a front roll-bar (or of two lateral roll-bars), their connecting members, one diagonal member, backstays and mounting points. (For example, see drawings 253-3 and 253-4).**

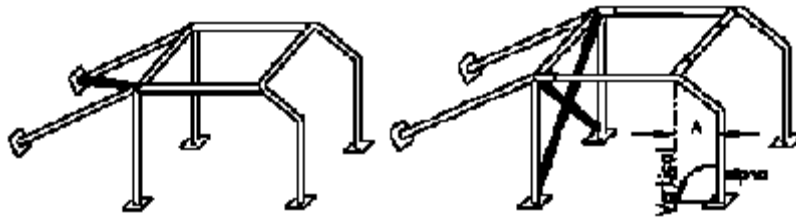

Drawing N° 253-3

Drawing N° 253-4

- b) **Main roll-bar: Structure consisting of a near-vertical frame or hoop located across the vehicle just behind the front seats.**
- c) **Front roll-bar: Similar to main roll-bar but its shape follows the windscreen pillars and top screen edge.**
- d) **Lateral roll-bar: Structure consisting of a near-vertical frame or hoop located along the right or left side of the vehicle. The rear legs of a lateral roll-bar must be just behind the front seats. The front leg must be against the screen pillar and the door pillar such that it does not unduly impede the entry or exit of driver and co-driver.**
- e) **Safety cages must be designed and made so that, when correctly installed, they substantially reduce body-shell deformation and so reduce the risk of injury to occupants.**
- f) **The essential features of safety cages are sound construction, designed to suit the particular vehicle, adequate mountings and a close fit to the body-shell.**
- g) **Tubes must not carry fluids.**
- h) **The safety cage must not unduly impede the entry or exit of the driver and co-driver.**
- i) **Members may intrude into the occupant's space in passing through the dashboard and front side-trim, as well as through the rear side-trim and rear seats.**
- j) **The rear seat may be folded down.**
- k) **Longitudinally, the safety cage must be entirely contained between the mounting points of the front and rear suspension elements carrying the vertical loads (springs and shock absorbers).**
- l) **Supplementary reinforcements exceeding these limits are authorized between the safety cage and the anchorage points of the rear anti-roll bars on the body-shell.**
- m) **A diagonal member is compulsory. For examples of different ways of fitting the compulsory diagonal member see drawings 253-3 to 253-5. The**

combination of several members is permitted according to drawings 253-3 and 253-5. The fitting of a second diagonal member, according to drawing 253-4, is recommended.

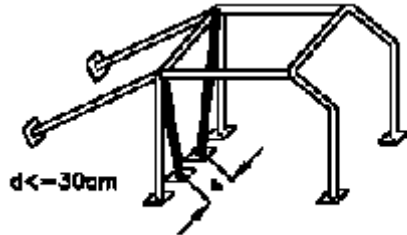

Drawing N° 253-5

- n) One or more door-bars (for side protection) longitudinal members must be fitted at each side of the vehicle (see drawings 253-7, 253-8, 253-12 and 253-17). They may be removable.

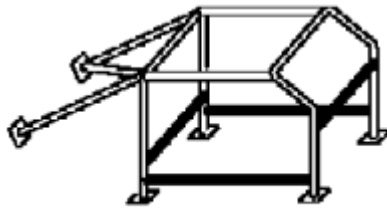

Drawing N° 253-7



Drawing N° 253-8

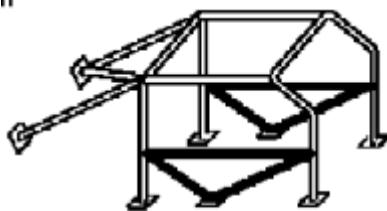

Drawing N° 253-12

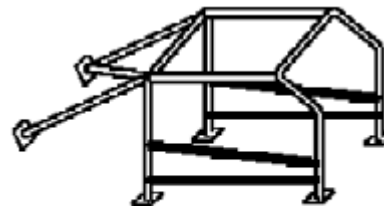

Drawing N° 253-17

- o) For competitions without co-driver, members may be fitted on the driver's side only.
- p) The side protection must be as high as possible, but its' upper attachment point must not be higher than half the height of the door opening measured from its base.
- q) If these upper attachment points are located in front of or behind the door opening, this height limitation is also valid for the corresponding intersection of the strut and the door opening.
- r) In the case of door-bars in the form of an "X" (cross-struts), it is recommended that the lower attachment points of the cross-struts be fixed directly onto the

- longitudinal member and that at least one part of the "X" be a single-piece bar.
- s) Specifications of the tubes used:
- i) Main roll bar, Lateral roll bar and their connections: Cold drawn seamless unalloyed carbon steel 40mm x 2.0mm (1.60" x 0.078") minimum.
  - ii) Other parts of safety cage: Cold drawn seamless unalloyed carbon steel 38mm x 2.5mm (1.5" x 0.098") or 40mm x 2mm (1.6" x 0.078").
- t) Main, front and lateral roll-bars must be made in one piece without joints. Their construction must be smooth and even, without ripples or cracks. The vertical part of the main roll-bar must be as straight as possible and as close as possible to the interior contour of the body-shell. The front leg of a front roll-bar or of a lateral roll-bar must be straight, or if it is not possible, must follow the windscreen pillars and have only one bend with its lower vertical part. Where a main roll-bar forms the rear legs of a lateral roll-bar (drawing 253-4), the connection to the lateral roll-bar must be at roof level. To achieve an efficient mounting to the body-shell, the original interior trim may be modified around the safety cages and their mountings by cutting it away or by distorting it. However, this modification does not permit the removal of complete parts of upholstery or trim. Where necessary, the fuse box may be moved to enable a roll-cage to be fitted.
- u) Mounting of roll-cages to the body-shell: Minimum mountings are:
- 1 for each leg of the main or lateral roll-bar.
  - 1 for each of the front roll-bar.
  - 1 for each backstay (see xi below).
- Each mounting foot of the front, main and lateral roll-bars must include a reinforcement plate, of a thickness of at least 3 mm (0.118") which must not be less than that of the tube onto which it is welded. Each mounting foot must be attached by at least three bolts on a steel reinforcement plate at least 3 mm (0.118") thick and of at least 120 cm<sup>2</sup> (7.322 inch<sup>2</sup>) area which is welded to the body-shell.

Examples are shown in Drawings 253-18 to 253-24 (for drawings 253-18 and 253-20, the reinforcement plate does not necessarily have to be welded to the body-shell).

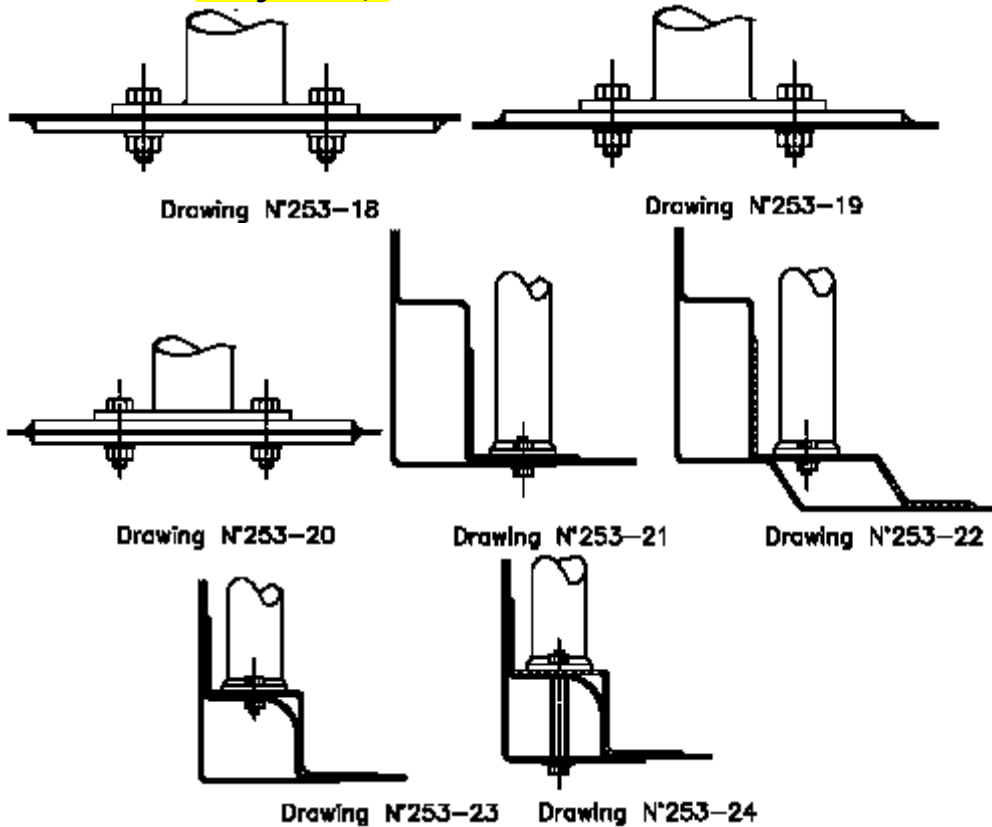

This does not necessarily apply to backstays (see item xi below).

Bolts must be of at least M8 size of ISO standard 8.8 or better.

Fasteners must be self-locking or fitted with lock washers.

These are minimum requirements. In addition to these requirements, more fasteners may be used, the roll-bar legs may be welded to reinforcement plates, and the roll-cage may be welded to the body-shell. Roll-bar mounting feet must not be welded directly to the body-shell without a reinforcement plate.

- v) Backstays: These are compulsory and must be attached near the roofline and near the top outer bends of the main roll-bar on both sides of the car. They must make an angle of at least 30° with the vertical, must run rearwards and be straight and as close as possible to the interior side panels of the body-shell. Their materials specification, diameter

and thickness must be as defined in Article 6.1.1 b viii.

Their mountings must be reinforced by plates. Each backstay should be secured by bolts having a cumulative section area at least two thirds of that recommended for each roll-bar leg mounting in Article 6.1.1 b x above, and with identical reinforcement plates of at least 60 cm<sup>2</sup> (9.30 inch<sup>2</sup>) area (see drawing 253-25). A single bolt in double shear is permitted, provided it is of adequate section and strength (see drawing 253-26) and provided that a bush is welded into the backstay.



Drawing N°253-25



Drawing N°253-26

- w) **Diagonal members:** At least one (1) diagonal member must be fitted. Their location must be in accordance with drawings 253-3 to 253-5 and they must be straight, not curved. The attachment points of the diagonal members must be so located that they cannot cause injuries. They may be made removable but must be in place during events. The lower end of the diagonal must join the main roll-bar of backstay not further than 100 mm (3.93") from the mounting foot. The upper end must join the main roll-bar not further than 100 mm (3.93") from the junction of the backstay joint, or the backstay not more than 100 mm (3.93") from its junction with the main roll-bar. They must comply with the minimum specification set out in Article 6.1.1 b viii. Diagonal members fixed to the body-shell must have reinforcement plates as defined in Article 6.1.1 b xi above.
- x) **Optional reinforcement of the roll-cage:** The diameter, thickness and material of reinforcements must be as defined in Article 6.1.1 b viii. They shall be either welded in position or installed by means of **dismountable joints**.
- vii) At least one (1) fire extinguisher to be within easy reach of the driver or passenger **(if applicable)**. Dry chemical type must have a minimum capacity of at least 2 kilogram.



- viii) An approved first aid kit.
- ix) **If the supplementary regulations of the event authorize them or impose them, transversal mud flaps will be accepted under the following conditions:**
  - a) **They must be made from flexible material.**
  - b) **They must cover at least the width of each wheel, but at least one third of the width of the car (see drawing 252-6) must be free behind the front wheels and the rear wheels.**
  - c) **There must be a gap of at least 20 cm between the right and left mud flaps in front of the rear wheels.**
  - d) **The bottom of these mud flaps must be no more than 10 cm from the ground when the car is stopped, with nobody on board.**
  - e) **Above and over the entire height of the tyre, at least 3/4 of the width of the tyre must be covered (seen from behind).**
  - f) **In vertical projection, these mud flaps must not protrude beyond the bodywork.**

**Mud flaps to prevent splashing towards the front, made from flexible material, may be installed at the front of the vehicle, if the supplementary regulations of the event authorize them or impose them.**

**They must not protrude beyond the overall width of the vehicle or beyond the original overall length by more than 10 cm, and at least one third of the width of the car must be free in front of the front wheels.**

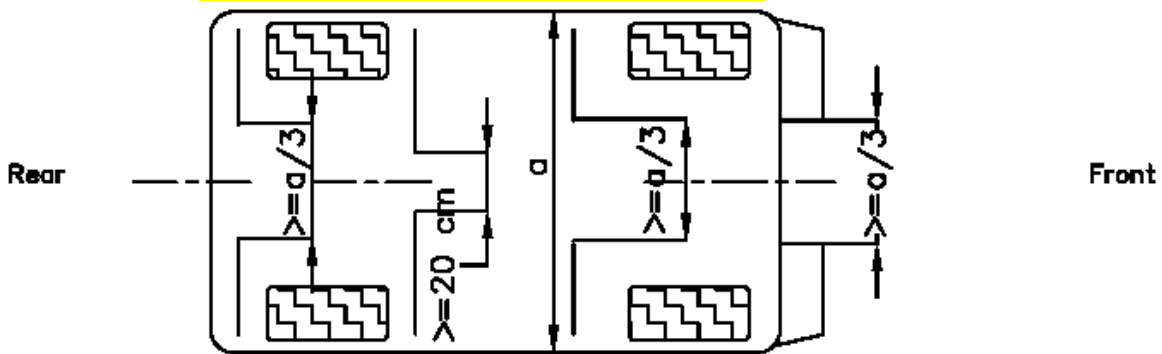

Drawing N° 252-6

- xi) a) **All the occupants' seats must be homologated by the EEC, the FMVSS or the FIA (8855/1999 standard) and not modified, or produced by a recognized manufacturer approved by the Competition Committee.**

In all these cases, a headrest must be present for each occupant.

b) If the original seat attachments or supports are changed, the new parts must either be approved for that application by the seat manufacturer or must comply with the following specifications (see drawing 253-52):

i) Supports must be attached to the shell/chassis via at least 4 mounting points per seat using bolts with a minimum diameter of 8 mm and counterplates, according to the drawing.

The minimum area of contact between support, shell/chassis and counterplate is 40 cm<sup>2</sup> for each mounting point.

If quick release systems are used, they must be capable of withstanding vertical and horizontal forces of 18000 N, applied non-simultaneously.

If rails for adjusting the seat are used, they must be those originally supplied with the homologated car or with the seat.

ii) The seat must be attached to the supports via 4 mounting points, 2 at the front and 2 at the rear of the seat, using bolts with a minimum diameter of 8 mm and reinforcements integrated into the seat.

iii) The minimum thickness of the supports and counterplates is 3mm for steel and 5mm for light alloy materials. The minimum longitudinal dimension of each support is 6 cm.

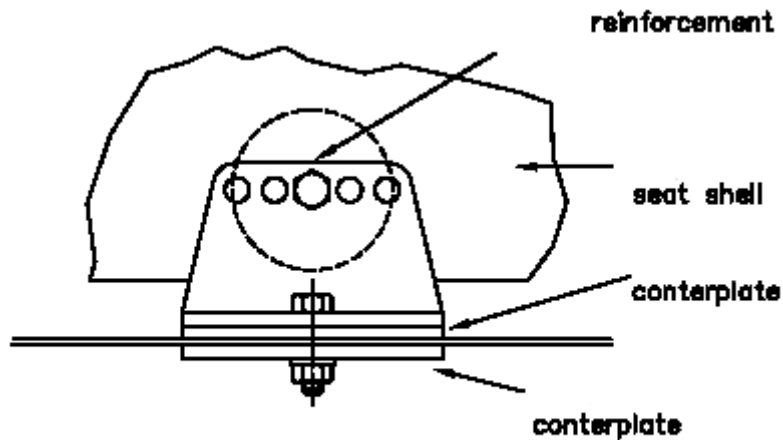

Drawing N°253-52

xii) The orifices of the exhaust pipes shall be placed at a maximum of 45cm and a minimum of 10cm from the

ground. The exit of the exhaust pipe must be situated within the perimeter of the car and less than 10cm from this perimeter, and aft of the vertical plane passing through the centre of the wheelbase. Moreover, adequate protection must be provided in order to prevent heated pipes from causing burns. Exhaust gas may only exit at the end of the system. Parts of the chassis must not be used to evacuate exhaust gasses.

### 6.1.2 Principles of Classification

- a) **All modifications are forbidden unless expressly authorized by the regulations specific to the group in which the car is entered or by the general prescriptions below or imposed under the chapter "Mandatory Safety Requirements".** If these Regulations do not specifically state modifications may be made or specific variations to OEM specifications are permitted, then no additional modifications or variations are permitted. This will be a major factor in the settling of any disputes arising from questions of eligibility. If a car is found not to comply with the technical regulations, it shall be no defense to claim that no performance advantage was obtained.
- b) Cars will be divided into three (3) groups:
  - i) Standard Production/JN
  - ii) Modified Production/JA
  - iii) Open Class/JC
- c) Group JN and JA must qualify as a legal **two** passenger vehicle minimum in their OEM specification.
- d) Group JN and JA will be further divided into classes in the following manner:

Class		Engine capacity (cc)
1	2WD	0 – 1400.
2	2WD	1401 – 1600.
3	2WD	1601 – 2000.
4	2WD	2001 and over.
7	4WD	0 – 3000.
8	4WD	3001 and over.

**2WD means Two Wheel Drive, 4WD means Four Wheel Drive**

- e) Group JC will be further divided into classes in the following manner:

Class	Engine capacity (cc)
1 2WD & 4WD	Up to 3000cc

- f) In cases of forced induction, the nominal cylinder-capacity will be multiplied by 1.7 for petrol engines and by 1.5 for diesel engines, and the car will pass into the class corresponding to the fictive volume thus obtained.  
The car will be treated in all respects as if its cylinder-capacity thus increased were its real capacity.  
This shall particularly be the case for assigning the car to its cylinder-capacity class, its minimum weight, etc.
- g) To be classified in Groups JA & JN, all vehicles employing a system of forced induction shall be fitted with a restrictor fixed to the compressor housing. All the air necessary for feeding the engine must pass through this restrictor which must respect the following;  
For Group JA:  
The maximum internal diameter of the restrictor is 34mm, maintained for a minimum distance of 3 mm measured downstream of a plane perpendicular to the rotational axis situated at a maximum of 50 mm upstream of a plane passing through the most upstream extremities of the whole blades (see drawing 254-4).  
This diameter must be complied with, regardless of the temperature conditions.  
The external diameter of the restrictor at its narrowest point must be less than 40 mm, and must be maintained over a distance of 5 mm to each side.  
The mounting of the restrictor onto the turbocharger must be carried out in such a way that two (2) screws have to be entirely removed from the body of the compressor, or from the restrictor, in order to detach the restrictor from the compressor.  
Attachment by means of a needle screw is not authorized.  
For the installation of this restrictor, it is permitted to remove material from the compressor housing, and to add it, for the sole purpose of attaching the restrictor into the compressor housing.  
The heads of the screws must be pierced so that they can be sealed.  
The restrictor must be made from a single material and may be pierced solely for the purpose of mounting and sealing, which must be carried out between the mounting screws, between the restrictor (or the restrictor/compressor housing attachment), the compressor housing (or the housing/flange attachment) and the turbine housing (or the housing/flange attachment) (see drawing 254-4).

In case of an engine with two parallel compressors, each compressor must be limited by a restrictor with a maximum internal diameter of 24.0 mm and a maximum external diameter of 30 mm, in the conditions set out above.

For Group JN:

All vehicles employing a system of forced induction shall be fitted with a restrictor fixed to the compressor housing. All the air necessary for feeding the engine must pass through this restrictor which must respect the following:

The maximum internal diameter of the restrictor is 32mm, maintained for a minimum distance of 3 mm measured downstream of a plane perpendicular to the rotational axis situated at a maximum of 50 mm upstream of a plane passing through the most upstream extremities of the wheel blades (see drawing 254-4).

This diameter must be complied with, regardless of the temperature conditions.

The external diameter of the restrictor at its narrowest point must be less than 38 mm, and must be maintained over a distance of 5 mm to each side.

The mounting of the restrictor into the turbocharger must be carried out in such a way that two screws have to be entirely removed from the body of the compressor, or from the restrictor, in order to detach the restrictor from the compressor.

Attachment by means of a needle screw is not authorized.

The heads of the screws must be pierced so that they can be sealed.

The restrictor must be made from a single material and may be pierced solely for the purpose of mounting and sealing, which must be carried out between the mounting screws, between the restrictor (or the restrictor/compressor housing attachment), the compressor housing (or the housing/flange attachment) and the turbine housing (or the housing/flange attachment) (see drawing N° 254-4).

In case of an engine with two parallel compressors, each compressor must be limited to a maximum intake diameter of 22.6 mm.

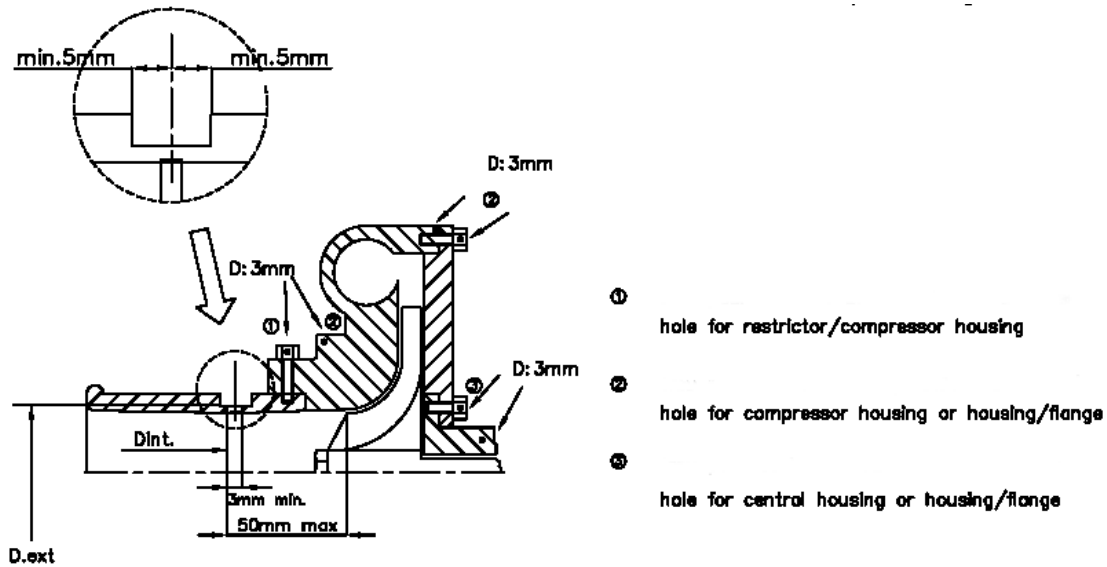

Drawing N°254-4

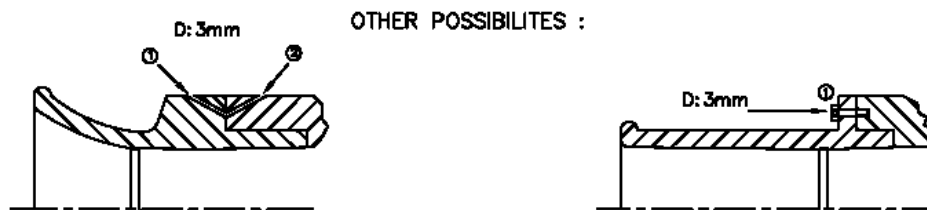

The following is an example:

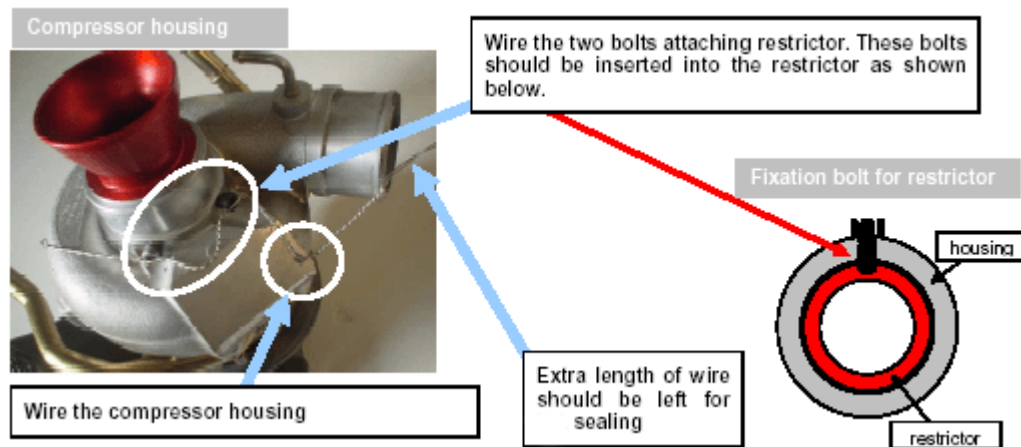

- h) In order to determine the classification of a car using an engine of the NSU Wankel patents (Rotary Engines), the manufacturers claimed cylinder displacement will be increased by a factor of 2. If the same engine also employs a system of forced induction, then the above rule Article 6.1.2.f shall also apply. (For example a Mazda 13B engine rated at 1308cc would

be classified as (1308x2) 2616 cc, if the same engine was turbo charged then the displacement would be (1308 x 2 x 1.7) 4447.2 cc.

- i) The use of Nitrous Oxide (N<sub>2</sub>O) is forbidden in all groups and classes.

**Only air may be mixed with the fuel as an oxidant. Racing gasoline, gasoline, methanol, gasohol, diesel, ethanol, natural gas and propane are permitted. Nitromethane is prohibited.**

### **6.1.3 Standard Production (JN)**

- a) All the modifications which are not allowed by these regulations are expressly forbidden. The only work which may be carried out on the car is that necessary for its normal servicing, or for the replacements of parts worn through use or accident. The limits of the modifications and fittings allowed are specified hereinafter. Apart from these, any part worn through use or accident can only be replaced by a part identical to the damaged one.

- b) Vehicles shall be at least the manufacturer's specified Kerb Weight with a standard tool-kit as supplied with the car, a maximum of one spare wheel, but without auxiliary lights, guards or roll cage. In the case where the roll cage has already been installed, the weight of the roll cage will be assessed at either 25kg. (55 lbs.) or 30 kg. (66 lbs.) depending on design.

**In cases where the vehicle is offered in alternate markets with different Kerb weights, the lowest weight may be used, provided that this is properly documented with the Competition Committee.**

- c) Exhaust system:

- i) The exhaust system downstream of the exhaust manifold exit is free, but must extend to the rear of the car and exit in the approximate location of the original system.
- ii) For cars with a turbo charger, the exhaust system begins after the turbo charger.
- iii) These liberties must not entail any bodywork modifications and must respect the laws of the land with regard to noise levels. **For all cars used in Rallies and unless the limits imposed by the local authorities are lower, the noise level on the open road must not exceed 103 dB(A) at 10ft measured at a 45° angle to the actual point of exit for an engine rotation speed of 3500rpm for petrol engines and 2500rpm for diesel engines.**

- d) Brake and Clutch:

- i) **The clutch disc is free, including the weight, with the exception of the number. The diameter of the clutch disc may be increased.**

The use of Carbon Fibre is prohibited.

- ii) Brake backing plates may be removed or bent.
  - iii) In the case of a car fitted with servo-assisted brakes, this device may be disconnected. The same applies for anti-lock braking systems.
  - iv) Brake lines may be changed for aviation type lines. Rerouting of brake lines is free.
  - v) A device for scraping away the mud which collects on the brake discs may be added. The mechanism of the handbrake lever may be adapted in order to maintain instant unlocking (fly-off handbrake). **The mechanical handbrake may be replaced with a hydraulic system.**
  - vi) An alternate brake proportioning valve is allowed, and the OEM brake proportioning valve may be modified or removed.
  - vii) **The electronic control unit of the braking system is free, but must be entirely interchangeable with the original unit (i.e. the braking system must work when the unit is replaced with the series unit.**
  - viii) **Brake linings are free, as well as their mountings (riveted, bonded, etc.) provided that the contact surface of the brakes is not increased.**
  - ix) **It is permitted to add a spring in the bore of the calipers and to replace the seals and the dust covers of the calipers.**
- e) Drive Train:
- i) **The interior of the gearbox, number of teeth and ratios is free. The gear selection grid pattern homologated on the series model must be retained. The use of a mechanical type limited slip differential is authorized, provided that it can be fitted in the series housing. "Mechanical limited slip differential" means any system which works purely mechanically, i.e. without the help of a hydraulic or electric system. A viscous clutch is not considered to be a mechanical system. If the original vehicle is fitted with a differential controlled by an electronic system, the electronic control unit is free, but must be entirely interchangeable with the original unit (i.e. the differential must work when the unit is replaced with the series unit). The joints of the gearbox linkage are free.**
- f) Suspension:
- i) The material of the elastic part of bushings and mounts is free but not the number or location.
  - ii) **The reinforcing of the structural parts of the suspension (with the exception of anti-roll bars) and its anchorage points by the addition of material is allowed. The suspension reinforcements must not create hollow sections**



**and must not allow two separate parts to be joined together to form one.**

- iii) Body shells may be seam welded and transverse strut braces may be fitted.
  - iv) Springs and dampers are free provided that the locating points remain unaltered.
  - v) **The modification of spring and shock absorber adjustments from the cockpit is prohibited.**
  - vi) **The damper tanks may be attached onto the unmodified shell of the cars. If the shock absorbers have separate fluid reserves located in the cockpit, or in the boot if this is not separated from the cockpit, these must be strongly fixed and must have a protection.**
  - vii) Anti-roll bars may be added or removed, however the addition must serve only one function.
- g) Engine:
- i) The accelerator cable may be replaced or doubled by another one regardless of whether it comes from the manufacturer or not. **If the series vehicle is fitted with a motorized throttle valve, a throttle kit with a mechanical linkage, homologated in Group N, may be used.**
  - ii) Ignition: The make and type of the spark plugs, rev. limiter and high tension leads are free. The electronic control unit and the ignition components in the electronic control unit are free; **nevertheless the system must be entirely interchangeable with the original unit. The original loom must be kept and cannot be modified.**  
Sensors and actuators on the input side must be standard, as must their function.
  - iii) Cooling System: The thermostat is free as is the control system and the temperature at which the fan cuts in. Locking system for the radiator cap is free.
  - iv) Carburetor: Jets are free.
  - v) Injection: The original system must be retained. The interior of the electronic control unit for the injection is free. Inputs to the electronic control unit (sensors, actuators, etc.), including their function must remain as standard.  
**The injectors may be modified or replaced in order to modify their flow rate, but without modifying their operating principle and their mountings.**  
**The injector rail may be replaced with another of free design but fitted with threaded connectors for connecting the lines and the fuel pressure regulator, provided that the mounting of the injectors is identical to the original.**

- vi) Replacement air filter cartridges are accepted in the same way as the original ones.
  - vii) The fitting of baffles in the oil sump is authorized.
  - viii) The material of the elastic part of the engine mountings is free, but not the number of engine mountings.
  - ix) Re-boring of the cylinder is allowed as per the OEM service manual.
  - x) **Engine shields made of plastic material, the purpose of which is to hide mechanical components in the engine compartment, may be removed if they have a solely aesthetic function.**
  - xi) **The material of the cylinder head gasket is free, but not the thickness.**
- h) Lubricants and Fluids:
- i) Lubricants and Fluids are free.
- i) Bodywork exterior:
- i) Hubcaps must be removed.
  - ii) Protective headlight covers may be fitted provided that their only function is to cover the glass, and that they have no influence on the car's aerodynamics.
  - iii) The fitting of underbody protection is authorized, **provided that these really are protections which respect the ground clearance**, which are removable and which are designed exclusively and specifically in order to protect the following parts: engine, radiator, suspension, gearbox, tank, transmission, exhaust, extinguisher bottles. **Underbody protections may extend the whole width of the underside part of the front bumper only in front of the front wheel axis.**
  - iv) Any locking system may be used for the cap of the fuel tank.
  - v) The fitting of external rear view mirrors is authorized.
  - vi) **The changing of the front and rear windscreen wiper blades is authorized.**
  - vii) **Plastic sound-proofing parts may be removed from the wheel openings. These plastic elements may be changed for aluminium or plastic elements of the same shape.**
  - viii) **The jacking points may be strengthened, moved and increased in number. These modifications are limited exclusively to the jacking points.**
  - ix) **Additional accessories: All those which have no influence on the car's behaviour, for example equipment which improves the aesthetics or comfort of the car interior (lighting, heating, ventilation, radio, etc.), are allowed without restriction. In no case may these accessories increase the engine power or influence the steering,**

**transmission, brakes, or road-holding, even in an indirect fashion.**

j) Bodywork Passenger space:

- i) All accessories which have no effect on the vehicle's behavior are allowed without restrictions, such as those concerning the aesthetics or interior comfort (lighting, A/C, radio, etc.), on the express condition that they do not influence, even in a secondary manner, the efficiency of the engine, steering, strength, transmission, braking or road-holding.
- ii) Additional measuring instruments, counters, etc. may be freely installed, provided that their fitting is not likely to create any danger.
- iii) Additional compartments may be added to the glove compartment as well as additional pockets to the doors.
- iv) The steering wheel is free. The locking system of the anti-theft steering lock may be rendered inoperative.
- v) Carpets, rear safety belts and rear seats may be removed and the front seats shall be replaced with competition items. **The front seats may be moved backwards but not beyond the vertical plane defined by the front edge of the original rear seat.**
- vi) **Should the fuel tank be installed in the boot and the rear seats removed, a fireproof and liquid-proof bulkhead must separate the cockpit from the fuel tank.**
- vii) **It is permitted to remove the soundproofing material from the doors, provided that this does not modify the shape of the doors.**
  - a) **It is permitted to remove the trim from the doors together with their side protection bars in order to install a side protection panel which is made from composite materials. The minimum configuration of this panel must comply with that shown on drawing N° 255-14.**

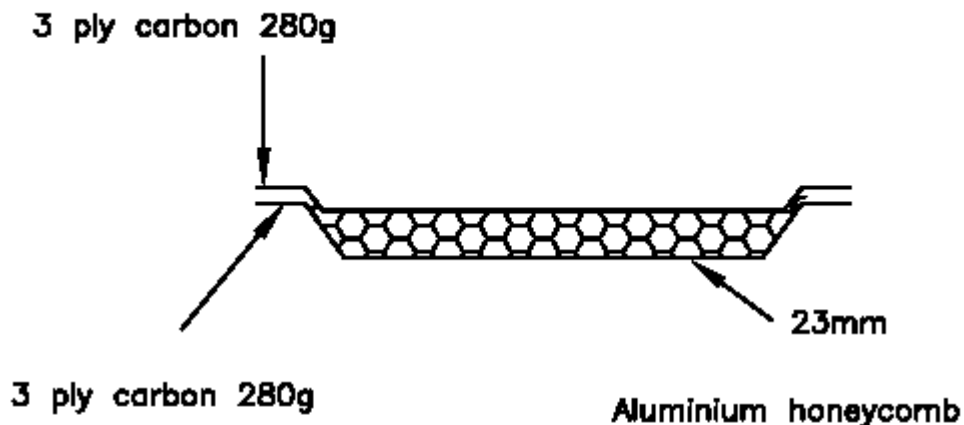

Carbon 4/4 twin 280gms E620

Aluminium honeycomb 23mm 1/8" cel4.5 or 6.35

#### Drawing N°255-14

- b) If the original structure of the doors has not been modified (removal, even partially, of the tubes or reinforcements), the door panels may be made from metal sheeting at least 0.5 mm thick, from carbon fibre at least 1 mm thick or from another solid and non-combustible material at least 2 mm thick.
- The rules mentioned above also apply to the trim situated beneath the rear side windows of two-door cars.
- The minimum height of the door's side protection panel must extend from the base of the door to the maximum height of the door strut.
- viii) Other soundproofing materials and trim, except for those mentioned under articles 6.1.3.j.vii may be removed. The dashboard and the central console must remain original.
- ix) It is permitted to replace electric winders with manual ones.
- x) The original heating equipment must be retained. The following parts of the air conditioning system may be removed: compressor, condenser and auxiliary fan, fluid tank, evaporator and fan, expansion valve, as well as all pipes, connections, contact switches, sensors and actuators necessary for the functioning of the system. If certain

- elements are common with the heating system, they must be retained.
- xii) **The removable rear shelf in twin-volume cars may be removed.**
  - xiii) **All controls must retain the role laid down for them by the manufacturer. They may be adapted to facilitate their use and accessibility, for example a longer handbrake lever, an additional flange on the brake pedal, etc.**
  - xiii) **The original fitting of the air bags may be removed, without modifying the appearance of the bodywork.**
- k) Electrical System:
- i) The make and capacity of the battery is free. Battery cables are free. The site of the battery must be retained. **A power take-off connected to the battery is permitted in the passenger space.**
  - ii) Alternators and generators are free.
  - iii) Additional headlights including the corresponding relays are allowed, provided that the total does not exceed eight (tail and parking lights not included). **The original headlights can be made inoperative and covered with adhesive tape. They can be replaced by other headlights, in compliance with this article.**
  - iv) A reversing light may be fitted provided it can only be used when the gear lever is in the "reverse" position, and provided that the Police regulations on this subject are observed.
  - v) Fuses may be added to the electrical system.
  - vi) The horn may be changed. Another one, possibly for the passenger's use, may be added. **In rallies only, the noise level produced by the horn must be greater than or equal to 97 dB during at least 3 seconds, measured 7m in front of the vehicle.**
- l) Wheels and Tyres:
- i) **The rims are free, respecting the homologated maximum diameter and maximum width. Where homologation information is not available from the Competition Committee, the diameter and width may be varied by 1" from OEM specification. The use of rims with lesser dimensions is permitted.**
  - ii) **Complete wheels (rim and tyre assembly) are free, provided that they may be housed within the bodywork. This means that the upper part of the complete wheel, located vertically over the wheel hub centre, must be covered by the bodywork when measured vertically. The**

**maximum wheel (rims and tyre assembly) diameter may not exceed 650 mm. (25.5").**

**Tyres are restricted to D.O.T or TUV approved only.**

- iii) Alloy rims are permitted. **Rims made from forged magnesium are forbidden (including standard rims).**
- iv) In no case may the width of the complete wheel (rim and tyre assembly), in relation to the cubic capacity of the associated engine exceed those dimensions indicated in the following table.

Engine Capacity (cc X conv. Factor)	Max wheel width inches	Class
0 - <b>1400</b>	<b>8.0</b>	JN1 (2WD)
<b>1401</b> -1600	<b>8.0</b>	JN2 (2WD)
1601-2000	<b>9.0</b>	JN3 (2WD)
2001 and over	9.0	JN4 (2WD)
0-3000	<b>9.0</b>	JN7 (4WD)
3001 and over	<b>9.0</b>	JN8 (4WD)

**Measuring wheel width: The width is to be measured with the wheel mounted on the car, on the ground, the vehicle in race condition, driver aboard, at any point along the circumference of the tyre, except in the area in contact with the ground.**

- m) FIA Approved Fuel Cells (FT3, **FT3.5 & FT5**)
  - i) FIA approved fuel cells (FT3, **FT3.5 or FT5**) are optional.
  - ii) Providing the original tank is equipped with an electric pump and an interior filter, it is possible when using an FT3, **FT3.5 or FT5** tank to place a filter and a pump with identical characteristics to the OEM one outside. These parts must be protected in adequate fashion.
  - iii) The filler holes may not be located in the window panels.
  - iv) Fuel lines must be changed for aviation type lines if an FT3, **FT3.5 or FT5** tank is used, the route of these lines being free. Should an OEM tank be used, this change is optional.
  - v) **The fitting of a second fuel pump is authorized, but this must be only a spare fuel pump, i.e. it cannot operate in addition to the authorized pump. It must be connectable only when the car is immobile and by means of a purely mechanical device situated beside the pumps.**
- n) **The lines linking the power steering pump to the rack may be replaced with lines respecting the following:**

- i) These lines must have threaded or self-sealing connectors and an outer braid resistant to abrasion and flame (will not sustain combustion).
- ii) These must have a minimum burst pressure of 280 bar (4000 psi) at the minimum operating temperature of 232°C (450°F). If the operating pressure of the hydraulic system is greater than 140 bar (2000 psi), the burst pressure must be at least double the operating pressure.

#### 6.1.4 Modified Production (JA)

Excepting for the Mandatory Safety Requirements the only Regulations in this group (JA) are as follows:

- a) Complete wheels (rim and tyre assembly) are free, provided that they may be housed within the bodywork. This means that the upper part of the complete wheel, located vertically over the wheel hub centre, must be covered by the bodywork when measured vertically. **The rim diameter may be increased or reduced by up to 2 inches in relation to the original dimensions. However, the rim diameter must not exceed 18". The maximum diameter of the complete wheels is 650 mm (25.5"), not including the studs if studded tyres are used. Tyres are restricted to D.O.T or TUV approved only.**
- b) In no case may the width of the complete wheel (rim and tyre assembly), in relation to the cubic capacity of the associated engine exceed, nor the weight be less than, those dimensions indicated in the following table.

Engine Capacity (cc X conv. Factor)	Max wheel width ins,	Min weight kg./ lbs.	Class
0 - <b>1400</b>	<b>8.0</b>	0.59 / 1.29	JA1 (2WD)
<b>1401</b> -1600	<b>8.0</b>	0.53 / 1.17	JA2 (2WD)
1601-2000	<b>9.0</b>	0.47 / 1.02	JA3 (2WD)
2001 and over	9.0	0.37 / 0.81	JA4 (2WD)
0-3000	<b>9.0</b>	0.39 / 0.86	JA7 (4WD)
3001 and over	<b>9.0</b>	0.34 / 0.75	JA8 (4WD)

e.g. Minimum Weight = 1590 (cc rating) X 0.53 (Conversion Factor) = 842 kg.

**Measuring wheel width: The width is to be measured with the wheel mounted on the car, on the ground, the vehicle in race condition, driver aboard, at any point along the circumference of the tyre, except in the area in contact with the ground.**

- c) Exhaust noise level shall comply with the laws of the land. **For all cars used in Rallies and unless the limits imposed by the local authorities are lower, the noise level on the open road must not exceed 103 dB(A) at 10ft measured at a 45 degree angle to the actual point of exit for an engine rotation speed of 3500 rpm for petrol engines and 2500 rpm for diesel engines.**
- d) **Engine block must one of the versions offered by the manufacturer of the car (i.e.: Ford engine in a Ford car).**

### **6.1.5 Open Class (JC)**

Excepting for the Mandatory Safety Requirements the only Regulations in this group (JC) are as follows:

- a) Open cockpit and convertible vehicles may use a four (4) mounting point roll cage/bar of sound construction.
- b) Exhaust noise level shall comply with the laws of the land.

### **6.1.6 Vehicle Logbooks**

- a) A vehicle logbook, listing the particulars and equipment of the vehicle, should be presented by competitors at Technical Inspection.
- b) During Inspection, any technical deviations in the vehicle shall be noted in the vehicle's logbook by the Technical Inspector.
- c) If a vehicle is damaged during an event, it shall be noted in the logbook.
- d) Competitors who do not have a Vehicle Logbook available shall not delay the inspection of vehicles that have their logbook available, and shall arrange with the Technical Inspector an appropriate time for inspection of their vehicle prior to being accepted for competition.
- e) Vehicle logbooks are available from the Competition Committee.

### **6.1.7 Weighing of Vehicles**

- a) The onus is on the competitor to have the vehicle at the legal weight at all times during an event. When called upon to have a vehicle weighed the following shall apply:
  - i) Cars will be weighed under the supervision of a Competition Committee representative on a scale designated by the Competition Committee.
  - ii) The car must be presented with its gas tank(s) as close to empty as possible.
  - iii) Only one spare tyre, and a standard set of tools will be allowed during weighing.
  - iv) All articles which are not an integral part of the vehicle and its equipment must be removed.



- vi) Additional lights shall be removed.
- vii) **It is permitted to complete the weight of the car by one or several ballasts provided that they are strong and unitary blocks, fixed by means of tools with the possibility to fix seals, placed on the floor of the cockpit, visible and sealed by the Technical Inspectors.**

#### **6.1.8 Protest against a Vehicle**

- a) If a protest is lodged against a vehicle, the protestor shall clearly state the exact regulation(s) alleged to have been violated and shall additionally stipulate the component(s) that are to be inspected.
- b) The protestor shall be required to post a cash bond with the Competition Committee, the amount of which shall be determined by the Chief Steward, and shall be sufficient to cover the cost of any disassembly, inspection and reassembling by a qualified service technician. Such inspection shall be performed under the supervision of the Competition Committee or a designate.
- c) If the vehicle is found not to conform to these regulations, the cash bond shall be returned to the protestor and the inspection cost shall be borne by the entrant and/or driver of the inspected vehicle shall be subjected to disciplinary action.
- d) If the vehicle is found to be legal, the protestor will forfeit the cash bond to the Competition Committee, which shall be used to cover the inspection cost involved. Any amount remaining after costs will be returned to the protestor.



## Prescription 2005 - 1

Section 6 (Technical Regulations) of the JMMC Rules and Regulations, Article 6.1.3 l. iv and Article 6.1.4 b read in part as follows:

**“Measuring wheel width: The width is to be measured with the wheel mounted on the car, on the ground, the vehicle in race condition, driver aboard, at any point along the circumference of the tyre, except in the area in contact with the ground.”**

The general definition of circumference is a line or external boundary of a closed curvilinear figure or object. The more common definition of circumference within mathematics is the measure of the outer boundary (commonly called the perimeter) of an elliptical area, especially a circular area.

For the purposes of interpretation of this rule, the curvilinear figure is defined as that outer boundary (perimeter) formed by the tyre and rim when viewed in cross section and the measurement is to be taken at the section width of same. Please see diagram below for visual reference, the red outline being the circumference.

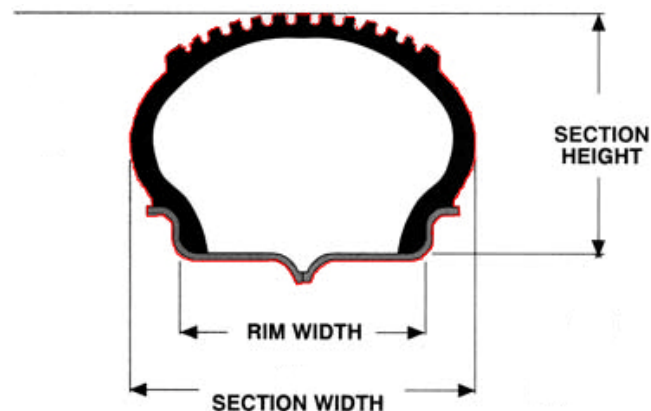

This means that the wheel (rim and tyre assembly) width is to be measured at the widest point of the section width under the conditions outlined in Article 6.1.3 l. iv and Article 6.1.4 b

**February 4, 2005**

**JMMC Competition Sub-Committee.**



# JAMAICA MILLENNIUM MOTORING CLUB

## Section 6

### Vehicle Requirements for Speed Events

Amendment 2005 – 002

Date: March 5, 2005

With immediate effect.

In regard to Article 6.1.3 I ii) and Article 6.1. 4 a) of Section 6 (Vehicle Requirements for Speed Events) of the Rules & Regulations of the JMMC.

Remove the wording “**Tyres are restricted to D.O.T or TUV approved only.**”

Add the following:

**All Tyres must be molded.**

**Tyres are restricted to:**

- a) **D.O.T. (United States Department of Transportation), JIS (Japan Industrial Standards) or ISO (International Organization for Standardization) approved.**
- b) **Competition tyres, the surface of which at the start of the event be taken up by grooves at least 1.6mm deep, with a maximum angle of 60° between the blocks in section (see diagram t-1) and 2mm wide and must occupy at least 10% of the total surface.**

**Surface, or tread pattern, is defined as per the following table.**

	<b>Length x Width</b>	<b>Surface</b>	<b>10% rate</b>
<b>9”</b>	<b>170 x 140</b>	<b>23800</b>	<b>2380</b>
<b>8.5”</b>	<b>161 x 140</b>	<b>22540</b>	<b>2254</b>
<b>8”</b>	<b>148 x 140</b>	<b>20720</b>	<b>2072</b>

7.5"	142 x 140	19880	1988
7"	133 x 140	18620	1862
6.5"	124 x 140	17360	1736

Length and Width dimensions are in millimeters (mm).  
Surface and 10% rate dimensions are in mm<sup>2</sup>.

The tread pattern must be molded.

Tyre cutting is authorized.

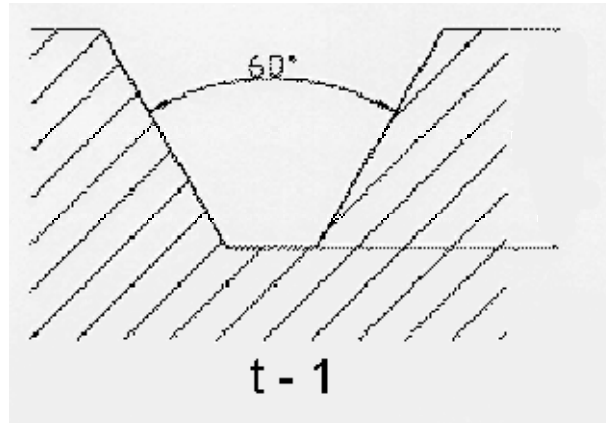

By authority of  
Competition Sub-Committee  
Jamaica Millennium Motoring Club



## **Prescription 2005 – 2**

*Further to Section 6 (Technical Regulations) of the JMMC Rules and Regulations, Article 6.1.3 l. ii and Article 6.1.4. a, please add the following text:*

All tyres must be treaded or grooved. In cross-section, 10% of the tread width must be made up of groves.

**Effective March 7, 2005.**

**JMMC Competition Sub-Committee.**

*(Published February 18, 2005)*



# JAMAICA MILLENNIUM MOTORING CLUB

## The Jamaica Millennium Motoring Club Championships Rules and Regulations

(Effective January 1, 2005)

### Index

1.	JMMC Club Championship	2
2.	Lady Club Championship	3
3.	Rookie Club Championship	3
4.	JMMC Rallysport Championship	4
5.	Lady Rallysport Championship	4
6.	Rookie Rallysport Championship	4
7.	Navigator Championship	4
8.	Sprint Championship	5
9.	2WD Sprint Championship	5
10.	Dexterity Championship	5
11.	Mug Rally Championship	6
12.	Organizer Championship	6
13.	Marshal Championship	6
14.	Navigational Rally Championship	7
15.	Stages Rally Team Championship	7
16.	Stages Rally Driver Championship	7
17.	Stages Rally Co-Driver Championship	7
18.	Stages Rally Class Driver Championship	8
19.	Stages Rally Class Co-Driver Championship	8
20.	Stages Rally 2WD Driver Championship	8
21.	Stages Rally 2WD Co-Driver Championship	8
22.	Stages Rally Entrant Team Championship	8
23.	Points	9
24.	Grades & Classification	9
25.	Points Schedule for Dexterity, Special Stage & Sprint Events	10
26.	Points Schedule for Mug Rallies	11
27.	Points Schedule for Major Rallies	12
28.	Points Schedule for Stages Rallies	13

The following annual awards shall be competed for by anyone with a valid membership and competition license of the Jamaica Millennium Motoring Club:-

- |     |                                           |                                                                                       |
|-----|-------------------------------------------|---------------------------------------------------------------------------------------|
| 1.  | JMMC Club Championship                    | - Overall 1 <sup>st</sup> , 2 <sup>nd</sup> , 3 <sup>rd</sup>                         |
| 2.  | Lady Club Championship                    | - Overall 1 <sup>st</sup> , 2 <sup>nd</sup> , 3 <sup>rd</sup>                         |
| 3.  | Rookie Club Championship                  | - Overall 1 <sup>st</sup> , 2 <sup>nd</sup> , 3 <sup>rd</sup>                         |
| 4.  | JMMC Rallysport Championship              | - Overall 1 <sup>st</sup> , 2 <sup>nd</sup> , 3 <sup>rd</sup>                         |
| 5.  | Lady Rallysport Championship              | - Overall 1 <sup>st</sup> , 2 <sup>nd</sup> , 3 <sup>rd</sup>                         |
| 6.  | Rookie Rallysport Championship            | - Overall 1 <sup>st</sup> , 2 <sup>nd</sup> , 3 <sup>rd</sup>                         |
| 7.  | Navigator Championship                    | - Overall 1 <sup>st</sup> , 2 <sup>nd</sup> , 3 <sup>rd</sup>                         |
| 8.  | Sprint Championship                       | - Overall 1 <sup>st</sup> , 2 <sup>nd</sup> , 3 <sup>rd</sup> & Class 1 <sup>st</sup> |
| 9.  | 2WD Sprint Championship                   | - Overall 1 <sup>st</sup> , 2 <sup>nd</sup> , 3 <sup>rd</sup>                         |
| 10. | Dexterity Championship                    | - Overall 1 <sup>st</sup> , 2 <sup>nd</sup> , 3 <sup>rd</sup> & Class 1 <sup>st</sup> |
| 11. | Lady Dexterity Championship               | - Overall 1 <sup>st</sup> , 2 <sup>nd</sup> , 3 <sup>rd</sup>                         |
| 12. | Mug Rally Championship                    | - Overall 1 <sup>st</sup> , 2 <sup>nd</sup> , 3 <sup>rd</sup>                         |
| 13. | Organizer Championship                    | - Overall 1 <sup>st</sup> , 2 <sup>nd</sup> , 3 <sup>rd</sup>                         |
| 14. | Marshal Championship                      | - Overall 1 <sup>st</sup> , 2 <sup>nd</sup> , 3 <sup>rd</sup>                         |
| 15. | Navigational Rally Team Championship      | - Overall 1 <sup>st</sup> , 2 <sup>nd</sup> , 3 <sup>rd</sup>                         |
| 16. | Stages Rally Team Championship            | - Overall 1 <sup>st</sup> , 2 <sup>nd</sup> , 3 <sup>rd</sup>                         |
| 17. | Stages Rally Driver Championship          | - Overall 1 <sup>st</sup> , 2 <sup>nd</sup> , 3 <sup>rd</sup>                         |
| 18. | Stages Rally Co-Driver Championship       | - Overall 1 <sup>st</sup> , 2 <sup>nd</sup> , 3 <sup>rd</sup>                         |
| 19. | Stages Rally Class Driver Championship    | - Class 1 <sup>st</sup> , 2 <sup>nd</sup> , 3 <sup>rd</sup>                           |
| 20. | Stages Rally Class Co-Driver Championship | - Class 1 <sup>st</sup> , 2 <sup>nd</sup> , 3 <sup>rd</sup>                           |
| 21. | Stages Rally 2WD Driver Championship      | - Overall 1 <sup>st</sup> , 2 <sup>nd</sup> , 3 <sup>rd</sup>                         |
| 22. | Stages Rally 2WD Co-Driver Champ.         | - Overall 1 <sup>st</sup> , 2 <sup>nd</sup> , 3 <sup>rd</sup>                         |
| 23. | Stages Rally Entrants Team Champ.         | - Overall 1 <sup>st</sup> , 2 <sup>nd</sup> , 3 <sup>rd</sup>                         |

## 1. JMMC Club Championship

### Eligibility

To be eligible for overall positions in the JMMC Club Championship, the following criteria shall apply: - (n.b. a & b are mandatory)

- a) Competition in 30% of all events on the competitions calendar\*

In the event that the percentages result in a fraction, the higher number of events shall be used. For example, if there are seven rallies on the calendar; 30% of this number results in the fraction 2.1; to be eligible a club member must have competed in three rallies.

\* Mug Rallies may not be used when calculating percentages.

- b) Assistance in organizing or marshaling at least three (3) events on the competitions calendar.
- c) Points are earned by the following:
  - i) Navigational Rally - Overall position
  - ii) Navigational Rallies with Stages - Overall & Class position
  - iii) Stage Rally - Class position
  - iv) Sprints and Dexterities - Class position
  - v) Organizing - Grades 1, 2 or 3
  - vi) Marshaling - Number of controls
- d) Points can only be allocated upon the recommendation of the Organizer / Secretary of the event. This will be subject to the ratification of the Competition Sub-Committee and the Executive Committee of the Jamaica Millennium Motoring Club.
- e) Once a competitor has crossed the start line and for whatever reason is unable finish the event as a competitor, he/she can opt to marshal that event. The points allocated will be based from being a competitor **or** an organizer / marshal **but not both**. These will count towards qualification for Clubman's and the relevant Championships.

## 2. Lady Club Championship

### Eligibility

- a) She must compete in at least three (3) events.
- b) Organize or marshal in three (3) events on the competitions calendar.
- c) Points are earned by the following:
  - i) Navigational Rally - Overall position
  - ii) Navigational Rallies with Stages - Overall & Class position
  - iii) Stages Rally - Class position
  - iv) Sprints and Dexterities - Class position
  - v) Organizing - Grades 1, 2 or 3
  - vi) Marshaling - Number of controls

## 3. Rookie Club Championship

### Eligibility

When a person joins the Jamaica Millennium Motoring Club for the first time, he / she is considered a Rookie and may qualify for the Rookie Club Championship as follows:

- a) If he / she joined the club before the first half of the championship year, then he/she will only be allowed to compete for the Rookie Club Championship once.
- b) If the member joined the club after the first half of the year, then he / she will be eligible to compete for the award twice providing he / she does not win the award on the first attempt.



- c) He / She must compete in at least three (3) events to include Rabbits & Hares, Mug Rallies and organize / marshal in at least two (2) events, including Mug Rallies.
- d) Points are earned by the following:
  - i) Navigational Rally - Overall position
  - ii) Navigational Rallies with Stages - Overall & Class position
  - iii) Stages Rally - Class position
  - iv) Sprints and Dexterities - Class position
  - v) Organizing - Grades 1, 2 or 3
  - vi) Marshaling - Number of controls

#### **4. JMMC Rallysport Championship**

##### Eligibility

- a) Must have competed in at least two (2) types of events.
- b) Points are earned by Drivers of the following:
  - i) Navigational Rallies with Stages - Class position
  - ii) Stages Rallies - Class position
  - iii) Sprints and Dexterities - Class position (JN/JA only)

#### **5. Lady Rallysport Championship**

##### Eligibility

- a) Must have competed in at least two (2) types of events.
- b) Points are earned by Drivers of the following:
  - i) Navigational Rallies with Stages - Class position
  - ii) Stages Rallies - Class position
  - iii) Sprints and Dexterities - Class position (JN/JA only)

#### **6. Rookie Rallysport Championship**

##### Eligibility

When a person joins the Jamaica Millennium Motoring Club for the first time, he / she is considered a Rookie and may qualify for the Rookie Rallysport Championship as follows:

- a) If he / she joins the club before the first half of the championship year, then he / she will only be allowed to compete for the Rookie Rallysport Championship once.
- b) If the member joined the club after the first half of the year, then he / she will be eligible to compete for the award twice providing he / she does not win the award on the first attempt.
- c) Must have competed in at least two (2) types of events.
- d) Points are earned by Drivers of the following:
  - i) Navigational Rallies with Stages - Class position
  - ii) Stages Rallies - Class position
  - iii) Sprints and Dexterities - Class position (JN/JA only)

## **7. Navigator Championship**

### Eligibility

- a) This award can only go to a navigator so specified on the entry form (there can only be one (1) navigator per car).
- b) He / She must have participated in at least two (2) Navigational Rallies (excluding Mug Rallies), and must qualify for the JMMC Club Championship as stated in Article 1.
- c) The maximum number of points, which can be accumulated, will come from the total number of navigational rallies held for the championship year.
- d) Points are earned by the following:
  - i) Navigational Rallies - Overall position
  - ii) Navigational Rallies with Stages - Overall position

## **8. Sprint Championship**

### Eligibility

- a) The maximum number of points which can be accumulated will come from the total number of sprint events held for the championship year.
- b) Points are awarded based on the results of the Championship run (**JN/JA only**) on that event. See Article 20a for point's allocation.
- d) In the event of a tie for championship position, the following criterion shall be used to break the tie in the order given:
  - i. Most events entered.
  - ii. Most wins.
  - iii. Highest placing.
  - iv. Share Championship.

## **9. 2WD Sprint Championship**

### Eligibility

- a) The top ten 2WD cars overall in each sprint event (**JN/JA only**), (not including the Championship run) will earn points based on Article 20a which will go towards the 2WD car sprint championship.
- b) In the event of a tie for Championship position, the following criterion shall be used to break the tie in the order given:
  - i. Most events entered.
  - ii. Most wins.
  - iii. Highest placing.
  - iv. Share Championship.

## **10. Dexterity Championship**

### Eligibility

- a) The maximum number of points will come from the total number of Dexterity events held for the championship year.

- b) Points are awarded based on the results of the Championship run on that event. See Article 20a for point's allocation.
- c) In the event of a tie for championship position, the following criterion shall be used to break the tie in the order given:
  - i. Most events entered.
  - ii. Most wins.
  - iii. Highest placing.
  - iv. Share Championship.

**11. Mug Rally Championship**

Eligibility

- a) Open to novices / rookies only.
- b) Total number of Mug Rallies events held for the championship year will count towards the Mug Rally Championship.
- c) Points are earned by the following:
  - i) Navigational Rally - Overall position
- d) A novice will be promoted to an Expert in the following manner: -
  - i) Any competitor who has placed 1st, 2nd or 3rd overall in a major rally. (Including Rabbits & Hares)
  - ii) Any competitor who has won two Mug Rallies.
  - iii) Any competitor who has won the Rabbits section of a Rabbits & Hares rally.
  - iv) Any competitor who has entered six rallies other than Mug rallies automatically qualify as an expert.
  - v) Any competitor who has won this championship automatically qualifies as an expert.

**12. Organizer Championship**

Eligibility

- a) An Organizer (Grade I, II or III) shall be recognized as a person who is actively involved in the organization / running of an event.
- b) A person who is an organizer may not be a competitor and vice versa.
- c) An organizer can only receive points for one function as an organizer of an event. The job with the most points will count towards the Organizer, JMMC Club, Lady Club and Marshal Championships.

Note: Organizer's are ultimately responsible for their event from start to finish including straightening out their financial accounts, all the paper work including results of the event(s) and the marshal lists are to be promptly handed over to the treasurer and the scorer respectively. Points can be deducted based on poor performance in duties; the amount will be determined by the Competition Sub-Committee.

**13. Marshal Championship**

- a) Points will be awarded based on the type of event(s) as per schedules 25(b), 26(c) and 27(c)
- b) MTC Marshals are excluded from this Championship. MTC Marshals will receive points towards the JMMC Club Championship, Organizer and Rookie Championships (Grade II).

Note. For this Championship only, non-members and unpaid members of the Jamaica Millennium Motoring Club are allowed to participate.

**14. Navigational Rally Team Championship**

Eligibility

- a) To be comprised of Driver and Navigator combination who have competed in two (2) navigational events as a “finished” combination.
- b) Must qualify for JMMC Club Championship as stated in Article 1.
- c) The maximum number of points which can be accumulated will come from the total number of navigational rallies held for the championship year (excluding Mug Rallies).
- d) Points are earned by the following:
  - i) Navigational Rallies - Overall position
  - ii) Navigational Rallies with Stages - Overall position

**15. Stages Rally Team Championship**

Eligibility

- a) This award will go to the team of Driver and Co-Driver.
- b) The maximum number of points which can be accumulated will come from the total number of stage rallies held for the championship year.
- c) Points are earned by the following:
  - i) Stages Rally - Overall position

**16. Stages Rally Driver Championship**

Eligibility

- a) This award can only go to the driver so specified on the entry form; (there can only be one (1) driver per car).
- b) The maximum number of points which can be accumulated will come from the total number of stages rallies held for the championship year.
- c) Points are earned by the following:
  - i) Stages Rally - Overall position

**17. Stages Rally Co-Driver Championship**

Eligibility

- a) This award can only go to the Co-Driver so specified on the entry form; (there can only be one (1) Co-Driver per car).

- b) The maximum number of points that can be accumulated will come from the total number of stages rallies held for the championship year.
- c) Points are earned by the following:
  - i) Stages Rally - Overall position

For 15, 16, and 17 the overall championship points are accumulated from Article 27(a)

**18. Stages Rally Class Driver Championship**

Eligibility

- a) This award can only go to the driver so specified on the entry form; (there can only be one (1) driver per car).
- b) The maximum number of points which can be accumulated will come from the total number of stages rallies held for the championship year.
- c) Points are earned by the following:
  - i) Stages Rally - Class position

**19. Stages Rally Class Co-Driver Championship**

Eligibility

- a) This award can only go to the Co-driver so specified on the entry form; (there can only be one (1) Co-driver per car).
- b) The maximum number of points that can be accumulated will come from the total number of stages rallies held for the championship year.
- c) Points are earned by the following:
  - i) Stages Rally - Class position

For 18 and 19 the class championship points are accumulated from Article 25a ii.

**20. Stages Rally 2WD Driver Championship**

Eligibility

- a) This award can only go to the driver so specified on the entry form; (there can only be one (1) driver per car). The maximum number of points that can be accumulated will come from the total number of stages rallies held for the championship year.
- b) The top eight highest placed overall 2WD cars in the following events earn driver's points:
  - i) Stages Rally - Overall position

**21. Stages Rally 2WD Co-Driver Championship**

Eligibility

- a) This award can only go to the Co-Driver so specified on the entry form; (there can only be one (1) Co-Driver per car). The maximum number of points which can be accumulated will come from the total number of stages rallies held for the championship year.

- b) The top eight highest placed overall 2WD cars in the following events earn Co-Driver's points:
  - i) Stages Rally - Overall position

For 20 and 21 the overall championship points are accumulated from Article 28.

**22. Stages Rally Entrant's Team Championship**

**Eligibility**

- a) To be comprised of a team of no more than three (3) Driver and Co-Driver combinations. This must be submitted to the scorer or Competition Sub-Committee prior to the start of the stages rally championship for that year. The names on the list can not be removed, replaced nor substituted nor be put on another list within that year. A fee of \$5,000.00 will be charged for the year on receipt of the list.
- b) The maximum number of points, which can be accumulated, will come from the total number of stage rallies held for the championship year. However the best two results from each team will be used from each stages rally.
- c) Points are earned by the following:
  - i) Stages Rally - Class position

**23. Points**

Competitors: Shall receive points for Dexterities, Rallies and Sprints in accordance with their pride of place and without any restrictions. (See points schedules 25a, 26a and 27a).

Class Champion: Points shall be allocated in accordance with overall class position on each event. (See point's schedule 25a ii).

Stages Rally Championships: Points shall be allocated in accordance with Overall Position on each event. (See points schedule 27a).

Entrant Team Championship: Points shall be allocated in accordance with class position on each event. (See points schedule 25a ii).

Organizers: Shall be allocated points as per grade of organizer (Refer to Article 24 and points schedules 25b, 26b, and 27b).

Marshals: Shall be allocated points as per type of event (See point's schedules 25b, 26c, and 27c).

**24. Grades & Classification**

Organizers shall be graded as follows:

- a) **Rallies:**
- Grade I - Organizer / Co-Organizer(s)
  - Grade II - Route Checkers / Route Setters / Opening & Closing Marshals / Clerk of the Course / Secretary / Stewards / Scorers / MTC Marshals
  - Grade III - Arrowing Personnel / Technical Inspectors / Banner Crew / Food Crew / Rally Head Quarters Personnel / Radio Personnel / Medics / Marshal Liaison / Marshal Welfare / Crowd Control

**n.b.** A separate scoring system exists for Marshals: (See Points Schedules 26c & 27c).

- b) **Dexterities and Sprints:**
- Grade I - Organizer (There shall be only one (1) Organizer)
  - Grade II - Co-Organizer / Clerk of the Course / Stewards / Secretary / Scorer / Route Setters
  - Grade III - Marshals / Timekeepers / Starters / Technical Inspectors / Announcers / Medics

**n.b.** A separate scoring system exists for Marshals: (See Points Schedules 25b).

**25. Points Schedule for Dexterity, Special Stage (Class) & Sprint Events**

- (a) **Competitors:**
- (i) Championship Round:

<u>Placing</u>	<u>Points</u>
1st	20
2nd	15
3rd	12
4th	10
5th	8
6th	6
7th	4
8th	3
9th	2
10th	1

**All Non-finishers are credited with 1/2 point.**

Class:	<u>3 Cars</u>	<u>4 - 6 Cars</u>	<u>7+ Cars</u>
<u>Placing</u>			
1 <sup>st</sup>	110	130	150
2 <sup>nd</sup>	70	100	110
3 <sup>rd</sup>	50	80	90
4 <sup>th</sup>		70	80
5 <sup>th</sup>		60	70
6 <sup>th</sup>		50	60
7 <sup>th</sup>			50
8 <sup>th</sup>			40
9 <sup>th</sup>			30
10 <sup>th</sup> +			20

All Non-finishers are credited with 10 points

- If only 1 car in a class the driver gets 50 points for finishing.
- If only 2 cars in a class the drivers get 70 & 50 points for finishing.

Points awarded are based on number of cars in each Class and will apply towards Class Championship as well as Clubman's and Driver's Championships and Co-Driver / Navigator where applicable.

(b) **Organizers & Marshals:**

Grade I	-	300
Grade II	-	175
Grade III	-	100

26. **Points Schedule for Mug Rallies**

(a) **Competitors:**

<u>Placing</u>	<u>Points</u>
1st	150
2nd	100
3rd	60
4th	40
5th	30
6th	24
7th	20
8th	16
9th	12
10th	8



Finishers	4
Non-finishers	2

(b) **Organizers:**

Grade I	-	175
Grade II	-	100
Grade III	-	60

(c) **Marshals:**

Shall earn 25 points for manning one (1) control and 20 points for each additional control.

A maximum of three (3) marshals may score points for manning any one (1) control.

All points gained from Articles 26b and 26c shall count towards the JMMC Club Championship.

**27. Points Schedule for major Rallies**

(a) **Competitors:**

Distance ( Km)

<u>Placing</u>	<u>100 - 150</u>	<u>151 - 350</u>	<u>351 - 500</u>	<u>501 - 750</u>	<u>751+</u>
1st	300	350	410	500	600
2nd	260	300	350	410	480
3rd	230	260	300	350	410
4th	210	230	260	300	350
5th	200	210	230	260	300
6th	190	200	210	230	260
7th	185	190	200	210	230
8th	180	185	190	200	210
9th	175	180	185	190	200
10th	170	175	180	185	190
11th	165	170	175	180	185
12th	160	165	170	175	180
13th	155	160	165	170	175
14th	150	155	160	165	170
15th	145	150	155	160	165
16th	140	145	150	155	160
17th	135	140	145	150	155

18th	130	135	140	145	150
19th	125	130	135	140	145
20th	120	125	130	135	140
21st to last finisher	110	115	120	125	130

Points above apply to each member of a 2 man crew - for 3 man crews less 10%.

(b) **Organizers:**

Distance (Km)	<u>100 - 150</u>	<u>151 - 350</u>	<u>351 - 500</u>	<u>501 - 750</u>	<u>751+</u>
Grade I	350	400	460	530	710
Grade II	260	280	310	350	400
Grade III	180	200	210	240	250

(c) **Marshals:**

Marshals shall be awarded 40 points for manning one (1) control and 30 points for each additional control.

A maximum of three (3) marshals may score points for manning any one (1) control.

Points earned by organizers and marshals as above will apply towards the Clubman's, Organizer's, Rookies and Marshal's Championships.

**28. Points Schedule for Stages Rallies**

Placing	Points
1 <sup>st</sup> place	10
2 <sup>nd</sup> place	8
3 <sup>rd</sup> place	6
4 <sup>th</sup> place	5
5 <sup>th</sup> place	4
6 <sup>th</sup> place	3
7 <sup>th</sup> place	2
8 <sup>th</sup> place	1



## Prescription 2008 – 002

### JMMC Dexterity Championship.

Points gained from Dexterities will be excluded from the JMMC Rallysport Championships. See applicable championships with new qualification criteria below.

All Dexterities MUST be sanctioned by the JMMC and will attract the applicable sanctioning fee. Dexterities will be required to have an ambulance available and on duty at the event venue. Engagement of a **doctor will be optional**.. All events must be insured –providing indemnity for the sanctioning body, host of the event and venue proprietor was is applicable.

Further to Section - Championship Regulations of the JMMC Rules and Regulations, and effective January 1, 2008, the following articles should read as below:

### 4. JMMC Rallysport Championship

#### Eligibility

a) Must **have competed in the at least one event from both the Sprint and Rally series for the calendar year**. Points are earned by Drivers of the following:

- i) Navigational Rallies with Stages - Class position
- ii) Stages Rallies - Class position
- iii) Sprints - Class position (JN/JA only)

### 5. Lady Rallysport Championship

#### Eligibility

a) Must **have competed in the at least one event from both the Sprint and Rally series for the calendar year**. Points are earned by Drivers of the following:

- i) Navigational Rallies with Stages - Class position
- ii) Stages Rallies - Class position
- iii) Sprints - Class position (JN/JA only)

### 6. Rookie Rallysport Championship

#### Eligibility

See section 3a & b for classification of a Rookie.

c) Must **have competed in the at least one event from both the Sprint and Rally series for the calendar year.** Points are earned by Drivers of the following:

- i) Navigational Rallies with Stages - Class position
- ii) Stages Rallies - Class position
- iii) Sprints - Class position (JN/JA only)

*Dated this 5<sup>h</sup> Day of January 2008*

**JMMC Competition Sub-Committee.**



# **JAMAICA MILLENNIUM MOTORING CLUB**

## **Circuit Racing General Regulations**

### **Table of Contents**

The Circuit Racing General Regulations is part of the JMMC Motor Sports Rules and Regulations. The Circuit Racing General Regulations shall be used in conjunction with Sections 1 and 2 of the Motor Sport Rules and Regulations.

Part 1	Administration
Part 2	Entries
Part 3	Registration & Technical Inspection
Part 4	Briefing
Part 5	Qualifying/Practice
Part 6	Starting Positions
Part 7	Assembly/Warm-up
Part 8	Starts
Part 9	Pit Regulations
Part 10	Track Regulations
Part 11	Flag Regulations
Part 12	Determination of Finish
Part 13	Code of Driving Conduct
Part 14	Stopping and Restarts
Part 15	Fuel
Part 16	Vehicle Logbook
Part 17	Weighing of Vehicles
Part 18	Dangerous or Unsuitable Drivers & Cars
Part 19	Injury to Drivers during the Meeting
Part 20	Protests
Part 21	General
Part 22	Points and Awards

### **Circuit Racing Regulations**

# **1            Administration**

## **1.1            Jurisdiction**

- (a) International Race meetings are held under the provisions of the JMMC Motorsports Rules and Regulations, General Regulations and its Appendices and Schedules (incorporating where not already provided for the provisions of the FIA Sporting Code).
- (b) National Race meetings are held under the provisions of the JMMC Motorsports Rules and Regulations, General Regulations and its Appendices and Schedules.

These are to be read in conjunction with any relevant Championship Series Articles.

## **1.2            Regulations**

These Regulations apply to all Race Meetings regardless of status.

## **1.3            Competition License Requirements**

Persons participating must be holders of the appropriate competition license as stated in the Motorsports Rules and Regulations.

# **2            Entries**

## **2.1            Entries, Dates & Fees**

Must be stated in the ASR's.

## **2.2            Number of Entries**

Maximum entries in each case are limited to the number of vehicles as prescribed for that type of vehicle on the track license.

## **2.3            Cancellation of Race**

The organizers reserve the right to cancel any race as long as provisions for doing so are made in the ASR's or for matters of Force Majeure.

## **2.4**

Unless specifically prohibited by the ASR's or by the articles of any Championship in respect of which an organizing permit has been issued, any entrant may, up to thirty (30) minutes prior to commencement of any race, with the written approval of the Clerk of the Course;

- (a) nominate the driver or change the driver nominated by the entrant, to drive the entrant's competing vehicle in the race.
- (b) change the competing vehicle entered in the race.

## **2.4            Dual Driver Entries**

Unless otherwise specified in the ASR's for each meeting, only one driver per car may be nominated except where a car is entered in more than one category or formula of competition.

## **2.6 Conditional Acceptance**

In the event of the number of entries exceeding the maximum number of starters, the Organizers reserve the right to accept entries conditionally. Organizers may accept entries on such conditions as the Organizers, as their sole discretion, impose.

## **2.7 Refund of Entry Fees**

If a withdrawal is made before the meeting and officially notified to the Race Secretary, and such withdrawal is accompanied by unused gate tickets, a refund will be paid at the discretion of the Organizing Committee. All applications for refunds must be in the hands of the Race Secretary no later than 28 days after the meeting.

# **3 Registration and Technical Inspection**

## **3.1 Registration**

Entrants and Competitors shall present themselves at registration for the checking of valid licenses, club membership etc., and are required to sign the relevant waivers.

## **3.2 Technical Inspection**

Entrants/Competitors shall present their cars and driving equipment etc. for inspection. Cars that have not passed Technical Inspection shall not be allowed on the race track.

## **3.3 Advertising**

The space requirements for advertising decals will be specified in either the Championship Articles, or the Supplementary Regulations. Failure to carry the specified decals may cause the competitor concerned to forfeit any points scored at the event. Advertising, names and symbols may be displayed on cars providing that they are in good taste and do not interfere with mandatory stickers, marks or symbols.

## **3.4 Accidents and Technical Inspection**

Any body damage incurred during practice or racing may necessitate the car being blacked-flagged and return to the pits forthwith for examination by the Technical Inspector. Following rectification (if any) such car may rejoin the race at the discretion of the Clerk of the Course. Cars withdrawn from practice or race due to accident damage may be impounded in the Technical Inspection bay for

examination by Technical Inspector. Such vehicles impounded will not be released to competitors other than upon the direction of the Technical Inspector.

## **4 Briefing**

### **Driver's Briefing**

The time, place and method of planned briefings shall be contained in the ASR's.

#### **4.1**

The Clerk of the Course or his nominee may brief drivers on important points or amplify matters regarding the conduct of the meeting. In the event that, the Clerk of the Course wishes to brief drivers further, a briefing meeting may be called at the time and place which will be notified to drivers and posted on the official Notice Board.

#### **4.2**

Competitors who fail to attend briefings may be penalized.

## **5 Qualifying / Practice**

### **5.1 Qualifying/Practice Sessions**

The schedule for Qualifying/Practice and Races shall be posted in the official program.

### **5.2 Qualifying is Mandatory**

- a) Unless specifically permitted by the Clerk of the Course, all drivers shall complete a minimum number of two timed qualifying laps.
- b) In the case of drivers who fail to appear for qualifying or do not qualify and have raced on the circuit previously, permission to race on race day may be given, but only at the discretion of the Clerk of the Course, in writing and shall state the grid position. If granted, such drivers shall start behind drivers who have posted a qualifying time. The decision of the Clerk of the Course on the matter will be final.

### **5.3 Discretionary Practice**

The Clerk of the Course has the discretion in exceptional circumstances, to permit further un-timed practice periods with the permission of the Stewards.

## **6 Starting Positions**

### **6.1 Starting Positions**

Starting positions shall be determined by:

- a) Lap times achieved in qualifying, fastest cars being to the front, or



- b) Finishing order in a preceding heat race, or
- c) Handicap, or
- d) Current positions in a Championship, or
- e) A method detailed in either Championship or Sanctioned Series Articles, or
- f) Clerk of the course approval as stated in the 5.2 b.

## **6.2**

Unless otherwise stated in the Supplementary Regulations or Championship/Sanctioned Series Articles, 6.1 a, shall apply.

## **6.3**

When starting positions are determined by qualifying times:

- a) Only those times established by a driver in an eligible car which they intended driving in the race will be recorded.
- b) All cars in an event must be given the opportunity to qualify with cars of the same Class.

## **6.4**

When identical times are recorded by more than one driver in the official qualifying session for that race, the driver first achieving such a time will receive the superior starting position.

## **6.5**

Starting positions shall be notified at least half an hour before the scheduled start, except when the finishing order in one event affects the starting positions in a subsequent event scheduled to start less than half an hour after the finish of the first event. In such instance, the starting positions shall be notified as soon as practicable.

## **6.6**

Display of starting positions on the official Notice Board will be considered notification to all drivers. It shall be the responsibility of the driver to ascertain the correct start position.

# **7 Assembly / Warm-up**

## **7.1**

Cars shall form up on the dummy grid under the directions of the Grid marshal, in starting order; the onus is on the driver to get his car on the dummy grid before the warm-up lap begins.

## **7.2**

Cars will be released from the dummy grid straight into a one lap warm-up. Should weather conditions change between practice and race, the Clerk of the

Course may, if in their opinion it is deemed necessary, allow an additional warm-up lap for the driver to fully determined track conditions.

### **7.3**

After the last car from the dummy grid has been released from the warm-up lap the track entrances shall be closed. Any cars that are late shall start from the pit exit, without doing a warm-up lap, when given the signal from the pit marshal. The Judge of Fact shall determined "lateness".

### **7.4**

There shall be no practice starts or weaving across more than 50% of the track width during warm-up. Any car weaving to the extent that in the opinion of the Clerk of the Course creates a danger to other competitors may be penalized. At the conclusion of the warm-up, cars will assemble in their allocated positions on the starting grid, under Starters' orders.

### **7.5**

There shall be a full course yellow flag condition when the warm-up leg begins and shall be in effect until the start of the race.

## **8 Starts**

### **8.1 Standing Starts**

Immediately the pole car is in position, the 30 second board will be shown to signal the start is imminent. Five seconds before the signal to start a five second board will be shown to announce the starter is intending to proceed with the actual start. The signal to start will be given by green light or flag drop.

- a) Grid Starts – Starts by Lights: The Starter will mount the dais and will switch on the red light for:
  - Not less and 4 seconds and not more than 7 seconds.
  - Between 4 and 7 seconds the Starter will switch on the green light to start the race.Where starting lights are employed, should an amber light be switched on after the red light is shown, then the 'start delayed' procedure will apply.
- b) Any driver in position on the grid but unable to take part in the start shall indicate their predicament by raising an arm to be clearly visible to the starter. The starter shall then take the appropriate action.
- c) False Start: Any car which has crossed its grid line before the starting signal has been given or which is moving forward when the starting signal is given, shall be deemed to have made a false start and shall be penalized.

### **8.2 Rolling Starts**

- a) A maximum of 20 seconds after the pole car is in the allocated position the field will be led away for the 'Rolling Start Lap' by the 'Safety/Pace Car'.
- b) All cars shall maintain their grid positions and keep up with the safety car. On approach to the start line, the safety car will turn off its flashing lights, accelerate and move off the circuit to a safe position. The field will then maintain the pace set by the car on the pole position. Drivers shall maintain their grid positions until the starting signal is given by flag or green light, after which racing will commence.
- c) If the starter is not satisfied with the field approaching the start line, the starting signal will not be given and the field will be required to complete another lap, maintaining their relative positions, to approach the starter again.

### **8.3 Delayed Starts**

If, through unforeseen circumstances, the start cannot take place at the appointed time, drivers shall be notified by the display of the Black Flag. The starting procedure will be recommenced when the condition is rectified.

### **8.4 Starts from Pits**

Any car missing the release from the dummy grid shall be deemed to be late and may start from the pit exit with the approval grid marshal. It may be moved to the pit exit only with the driver in position. Cars will join the race as soon as the field has been started, and the pit marshal gives the signal. Start procedures which by virtue of Circuit construction do not fit into this Rule, must be set out separately and clearly in the ASR's.

### **8.5 Multi-Part Events**

To be eligible to start in the second or subsequent part of a multi-part event, a driver (in that car) must have come under Starter's Orders in each of the preceding part(s), unless otherwise stated.

### **8.6 Evacuation of Signaling Area**

During the start of a race the pit wall must be kept completely free of people with the exception of properly authorized persons.

## **9 Pit Regulations**

### **9.1**

Drivers may receive assistance only:

- a) at the pits or paddock
- b) from officials

## **9.2**

Refueling of competition cars may only be carried out during practice in the paddock area. Work upon the cars, other than by a driver or officials may be carried out only in the pits or in the paddock.

For long distance events involving refueling, possible driver changes and work on vehicles, the ASR's will amplify these requirements.

## **9.3**

Any driver intending to leave the course, or to enter the pit or paddock area, shall signal their intention in good time and shall ensure that it is safe to do so.

## **9.4**

No competing vehicle shall be driven in the opposite direction except for the minimum distance to remove it from an unexpected situation and then only under official supervision.

## **9.5**

Cars may only leave the pit lane when the pit marshal gives the signal.

# **10**                    **Track Regulations**

## **10.1**

Except while on the track, no competing car shall be driven at a speed exceeding 15 km/h.

## **10.2**

Any vehicle, which has left the track with all four wheels, shall rejoin the track at the nearest point to the exit from it, compatible with safety.

## **10.3**

Should a driver be compelled to stop the car, either involuntarily or for any other reason, the car shall be moved off the track as soon as practical so that its presence does not constitute a danger, the driver must retire to a safe position. If the driver is not able to move the car out of the potentially dangerous position, it is the duty of the officials to assist. In that case if the driver succeeds in restarting the car without any other external help and rejoins the race without committing any breach of the regulations and without gaining an advantage from the preceding movement of the car to a safer place, the driver will not be excluded from the race.

## **10.4**

No vehicle able to proceed under its own power shall be stopped either on the course or the verges of the track, but shall proceed to the pits or paddock.

## **10.5**

Pushing a vehicle for the minimum distance to remove it from an unexpected situation is allowed and then only under official supervision.

## **10.6**

The pushing of a car by the driver or by another competing car along the track or pushing it across the finishing line is not allowed and will entail immediate exclusion of the car or cars concerned save as provided for above.

## **10.7**

All races will be run in the direction specified on the track license.

## **10.8**

The finish line must be marked on the track and will not extend beyond the actual track edges and thus will not include the pit-lane, unless provided otherwise.

## **10.9**

A driver shall, at all times, drive in a manner compatible with general safety and any penalty incurred under these Regulations shall not prevent any further action in respect of careless or reckless driving.

## **10.10**

In case of inclement weather or bad visibility, the Clerk of Course may deem it necessary for rain lights to be illuminated. Competitors will be advised of this requirement prior to the start of practice and/or race.

## **11 Flag Regulations**

### **11.1**

Officials' signals will be conveyed to drivers by the following signals:

#### **National Flag or Green Lights:**

At start line: Start.

#### **Light Blue Flag: Overtaking Signal**

Stationary: A faster car is catching you. Give way.

Waved: A faster car is trying to overtake you, give way.

#### **White Flag : Slow-moving vehicle on the track.**

At all times:

Stationary: You are about to catch a much slower vehicle.

Waved: You may be seriously obstructed by a much slower vehicle.

**Yellow Flag: Signal of danger. - DO NOT OVERTAKE!**

At all times:

Stationary: Drive well within your limits. **Do not overtake.** There is a hazard beside the track.

Waved: **Slow down. Do not overtake.** Be prepared to change direction or follow an unusual line. There is a hazard on the track.

Double Waved: **Slow down. Do not overtake.** Be prepared to stop. The track is wholly or partially blocked.

Once shown a yellow flag you do not overtake until you have passed a green flag marking the end of the danger area.

The yellow flag will normally be shown only at the marshal's post immediately preceding the hazard; the no-overtaking zone begins at the point where the flag is shown, a car ahead at that point keeping the advantage.

Overtaking is an offence from wherever Yellow Flags are displayed until the Green Flag is passed and drivers must maintain their relative positions within this zone until they pass the Green Flag.

**Yellow flag with Red Stripes: Deterioration of Adhesion.**

At all times:

Stationary: Deterioration of adhesion ahead. Waved: Deterioration of adhesion imminent.

**Green flag: All clear.**

At all times: All clear at end of danger area marked by Yellow Flag(s).

Optional Use: (By order of the Clerk of the Course) Start warm-up lap or start practice session.

**Red flag: Stop**

During Practice: The practice session has been stopped. Proceed slowly with maximum caution to your track-side pit. Be prepared to stop if requested.

During the Race: The race has been stopped. Proceed slowly with maximum caution to the starting grid and await further instructions. Be prepared to stop if requested.

**Black flag with Orange Disc displayed with White Number: Mechanical problem.**

At all times: A warning of apparent mechanical failure, or of a fire, which might not be obvious to you. You must call in at your pit on the next lap.

**Black and White Rectangular flag split diagonally and displayed with a White Number: Driver behavior.**

During the Race: A warning to you as the driver of the car bearing the number, that your behavior is suspect and that you will be Black flagged on further reports.

**Black flag displayed with White Number: Driver behavior.**

During the Race: You must stop at your pit within one lap of receiving the signal and report to the Clerk of the Course who has additional powers up to exclusion to apply if necessary.

**Black flag and Time penalty Board displayed with White Number:**

During the Race: Within one lap, you shall proceed to the designated area in the pit lane and shall remain there until authorized by the designated official to rejoin the race without stopping at your pits.

**Black and White Chequered flag:**

At all times: End of Race or Finish. End of practice.

If signal lights replace these flag signals, the lights must be approved by the ASN and fully detailed in the ASR's.

**12 Determination of the Finish**

**12.1**

The finish signal will determine the conclusion of a competition.

**12.2**

In the case of a race over a set distance, the winner shall be the competitor who covers the distance in the least time and the end of race signal will be displayed when the first competitor completes the set distance.

**12.3**

In the case of a race for a set time, the winner will be the competitor who covers the greatest distance in that time, and the end of race signal will be displayed to the leading car.

**12.4**

After receiving the end of race or practice signal, cars will maintain station and proceed at a reduced speed to the paddock, unless the ASR's specify that only part of a lap shall be covered.

**12.5**

To be classified as a finisher, a car must cross the finishing line under its own power, immediately after the signaling of the finish of the race and have covered at least 75% of the distance achieved by the appropriate class winner.

## **12.6**

Should the end of the race signal inadvertently or otherwise be displayed before the leading vehicle completed the scheduled number of laps - or before the prescribed race time has been completed - the race will nevertheless be deemed to end at the moment the signal is given. Should the end of race signal be inadvertently delayed, the race will nevertheless be deemed to finish at the correct moment and the competitors will be classified accordingly.

## **12.7           Dead Heats**

For any classification, dead heats will result in points gained or awards shared equally. Thus, if third and fourth places cannot be separated their points or awards are added together and divided by two, and these competitors declared equal third. The next competitor in the classification is declared to be fifth.

## **12.8           Ties in Championships, Cups, Trophies or Series**

Unless the Articles or ASR's provide otherwise, the classification in a Championship or Series which has resulted in a tie, will be determined by taking into account, firstly, the number of first placings obtained and progressing down the finishing positions in all the events counting for the Championship or Series until the tie is broken. If an equal result is still obtained, then a dead heat will be declared.

## **12.9           Provisional Results**

In accordance with the Motor Sports Rules and Regulations, the Provisional Results will be posted as soon as possible after each race and in the absence of any inquiries, complaints; protests or technical inspections pending will become final after the expiration of 30 minutes.

## **13               Code of Driving Conduct**

### **13.1**

During the race, a car alone on the track may use the full width of the track. However, as soon as it is caught up on a straight line by a car which is either temporarily or constantly faster, the driver shall maintain position on the track and indicate by signaling the side the faster driver should overtake on.

### **13.2**

Any driver appearing not to be making adequate use of the car's rear view mirror, or driving in a manner which even if unintentionally appears consistently



to hinder or discourage another driver seeking to pass, may be halted by display of the black flag or otherwise penalized.

### **13.3**

Curves, as well as the approach and exit zone thereof, may be negotiated by the drivers any way they wish, within the limits of the track. Overtaking, according to the circumstances prevailing, may be done either on the right or on the left. The onus is on the overtaking driver to ensure the maneuver is carried out safely. However, maneuvers liable to hinder other drivers such as premature direction changes, deliberate crowding of cars towards the inside or the outside of the curve or any other abnormal change of direction, are strictly prohibited and shall be penalized, according to the importance and repetition of the offences.

### **13.4**

The driver of any car leaving the race shall signal the intention in good time and is responsible for ensuring that the maneuver is carried out safely and as near as possible to the point of exit.

### **13.5**

Whilst practicing or competing, cars shall not be driven other than on the defined track, in the pits, and in such other areas as may be specified.

### **13.6**

For the duration of the meeting the competing vehicle, if used outside the confines of the track, shall be operated in compliance with the traffic regulations and at all times in a manner deemed not to prejudice the interests of motorsport.

## **14            Stopping and Restarts**

### **14.1            Stopping the Race or Practice**

Should it become necessary to stop the race or practice because the circuit is blocked by an accident or because weather or other conditions make it too hazardous to continue, the Clerk of Course shall order a red flag to be shown at the start line. Simultaneously, red flags will be shown at all Marshal Posts. The decision to stop the race or practice can only be taken by the Clerk of Course (or in his unavoidable absence, his Deputy). When the signal is given to stop:

- a) During practice, all cars shall immediately reduce speed and proceed slowly back to the pits. If it is impossible in the opinion of the Clerk of Course to restart the practice then the session shall be declared finished and all cars shall return to their respective pit paddock area.
- b) During a race, all cars shall immediately reduce speed and proceed slowly to the starting grid where they will remain in Parc Fermé conditions; no

intervention of any nature is authorized on the cars until specific direction is given to competitors.

The Clerk of Course, in consultation with Technical Officers and/or Technical Inspectors, may direct that: -

- Repairs on cars may start and if so where.
- Tyres may only be changed in the pits
- No work may start at all until after the restart.
- Refueling is permitted and if so where.
- Cars in the pits can go to the grid and if so how.
- Rain tyres must be fitted for the restart.
- Other actions are taken.

If no direction is given, the cars must stay in the condition in which they finished the first part.

## **14.2 Restarting the Race**

Unless the Regulations indicate otherwise, the following conditions will apply to races which have been stopped prior to their scheduled completion.

- a) If less than two laps have been completed by the leader, the race shall be restarted. All starters in the original start may compete again. No reserve entries will be admitted. The race will be considered a new race and the full time or distance covered.
- b) More than two laps have been completed but less than 75% of the scheduled distance or time:
  - The race shall be deemed to be in two distinct parts.
  - The finishing order and position shall be that as at the end of the lap preceding the showing of the red flag.
  - The distance or time of the second half will be that required to complete the scheduled distance or time.
  - The timekeepers taking the above into account will establish a new starting order. Only those still competing at the end of the first part of the event and who arrive at the starting grid under their own power and using an authorized route, will be allowed to compete in the second part. No reserve vehicles will be permitted.
- c) If it is impossible, in the opinion of the Stewards of the Meeting, to restart the event, then the Stewards shall declare the event finished and half points shall be awarded unless otherwise stated in the ASR's or Championship/Series articles.
- d) 75% of the scheduled distance or time has been completed: The race will be concluded and there will be no restart.

## **15 Fuel**

### **15.1**

The use of Nitrous Oxide (N<sub>2</sub>O) is forbidden in all groups and classes. Only air may be mixed with the fuel as an oxidant. Racing gasoline, gasoline, methanol, gasohol, diesel, ethanol, natural gas and propane are permitted. Nitromethane is prohibited.

## **15.2**

No fuel will be allowed in pits and all refueling will be carried out in the paddock, unless specified otherwise. Refueling arrangements and equipment will be inspected to ensure that there is no undue risk of fire and any faulty equipment will be condemned.

## **16**                    **Vehicle Logbook**

- a) A Vehicle Logbook, listing the particulars and equipment of the vehicle, should be presented by competitors at Technical Inspection.
- b) During Technical Inspection, any technical deviations in the vehicle shall be noted in the vehicle's logbook by the Technical Inspector.
- c) If a Vehicle is damaged during an event, it shall be noted in the logbook.
- d) Competitors who do not have a Vehicle Logbook available shall not delay the inspection of vehicles that have their logbook available, and shall arrange with the Technical Inspector. an appropriate time for inspection of their vehicle prior to being accepted for competition.
- e) Vehicle Logbooks are available from the JMMC.

## **17**                    **Weighing of Vehicles**

The onus is on the competitor to have the vehicle at the legal weight at all times during an event. When called upon to have a vehicle weighed the following shall apply:

- a) Cars shall be weighed under the supervision of the Technical Inspector or his designate on the official scale for the event.
- b) The car shall be presented with its gas tank(s) as close to empty as possible.
- c) All articles which are not an integral part of the vehicle and its equipment shall be removed.
- d) To complete the weight of the car by one or several ballast they shall be strong and of unitary blocks, fixed by means of tools with the possibility to fix seals, placed on the floor of the cockpit.
- e) For the purpose of arriving at 'weight' the weight ratios in the Circuit Racing Technical Regulations shall include an additional 120 pounds. (Thus the weight for an IP1 car shall be the cc X 1.125 + 120 lbs. with the driver on- board).

## **18**                    **Dangerous or Unsuitable Drivers and Cars**

The Promoters reserve the right to exclude either before or during the Meeting any car or driver which they consider to be unsuitable or unsafe.

## **19 Injury to Drivers during the Meeting**

Drivers involved in a collision and/or accident during racing or practice must obtain a clearance from the Chief Medical Officer and Clerk of Course before competing further in the Meeting.

## **20 Protests**

All Protests must be made in accordance with the Motor Sports Rules and Regulations.

## **21 General**

### **21.1 Safety Cars**

A Pace/Safety Car, which will be identified by a sign and/or Flasher lights, will be brought into operation to neutralize a race when deemed necessary by the Clerk of the Course. Amber lights or a Yellow Flag will be used at the start line and all flag points will then display yellow flags which shall be maintained until the Safety Car's intervention is over. Competing cars will line up behind the Safety Car unless signaled otherwise by the Safety Car, overtaking the Pace/Safety Car is forbidden. If signaled to pass the Safety Car, drivers will complete the circuit at reduced speeds without overtaking until reaching the line of cars behind the Safety Car. Whilst the Safety Car is in operation, competing cars may stop at their pit but may not rejoin the track while the Safety Car and the line of cars following it are passing the pit-exit. A car rejoining the track will proceed at reduced speed until it reaches the end of the line of cars behind the Safety Car.

When the Clerk of the Course decides to call in the Safety Car, the Safety Car shall extinguish the lights and proceed to a designated exit from the circuit.

When the Safety Car pulls off the circuit, a green flag or green light will be shown at the start-line. Overtaking remains strictly forbidden until the cars pass the green flag or light at the start-line. All flag points will then show the green flag for one lap.

### **21.2 Protests against a Vehicle.**

- a) If a protest is lodged against a vehicle, the protestor shall clearly state the exact regulation(s) alleged to have been violated and shall additionally stipulate the component(s) that are to be inspected.
- b) The protestor shall be required to post a cash bond with the Stewards, the amount of which shall be determined by the Chief Steward, and shall be sufficient to cover the cost of any disassembly, inspection and reassembling by a qualified service technician. Such inspection shall be performed under the supervision of the Stewards or a designate.

- c) If the vehicle found not to conform to these regulations, the cash bond shall be returned to the protestor and the inspection cost shall be borne by the entrant and/or driver of the inspected vehicle. In addition the entrant and/or driver of the inspected vehicle shall be subjected to disciplinary action.
- d) If the vehicle is found to be legal, the protestor will forfeit the cash bond to the Stewards, which shall be used to cover the inspection cost involved. Any amount remaining after costs will be returned to the protestor.

**21.3 Prohibited Area**

Only such persons and vehicles as may be in the opinion of the Organizers, necessary or essential for the conduct of the Meeting shall be permitted in the restricted areas. Access to such area by any person other than those for whose use passes are specifically issued or misuses of such passes may result in disciplinary action against any driver/entrant concerned.

**21.4 Circuit Advertising & Promotional Activity**

Erection of signs at the circuit during the meeting by drivers/entrants or their Sponsors is not permitted without the prior approval of the Organizers. All advertising banners and/or hoardings shall be in place before official practice commences. Once official practice has commenced there shall be no more banners or hoardings erected without the specific written approval of the Stewards and Clerk of Course.

**21.5 Official Notice Boards**

The location of the Official Notice Board shall be stated in the ASR's.

**21.6 Official Time of Day**

The Official Time of Day will be kept by the Chief Steward.

**21.7 Race Programme**

The race programme will be in accordance with the ASR's.

**22 Points and Awards**

**22.1 Championship Points**

Driver Race finishing points will each be awarded in each class as follows:

<b>Format 1</b>		<b>Format 2</b>		
		<b>Race 1</b>	<b>Race 2</b>	
<b>1<sup>st</sup></b>	10 points	<b>1<sup>st</sup></b>	4.0	6.0
<b>2<sup>nd</sup></b>	6 points	<b>2<sup>nd</sup></b>	2.4	3.6
<b>3<sup>rd</sup></b>	4 points	<b>3<sup>rd</sup></b>	1.6	2.4
<b>4<sup>th</sup></b>	3 points	<b>4<sup>th</sup></b>	1.2	1.8

5 <sup>th</sup>	2 points	5 <sup>th</sup>	0.8	1.2
6 <sup>th</sup>	1 point	6 <sup>th</sup>	0.4	0.6

**1 point for qualifying on Pole Position.**

## **22.2 Race Finishing, Scoring and Awards**

- a) To qualify as a race finisher, a competing vehicle must have completed no less than seventy five percent (75%) of the total race laps run by the class leader at the end of the race and shall also be running at the finish.
- b) Only race finishers are eligible to receive points for a race.
- c) In case of a tie in series point standings, the tie shall be resolved according to the record of first place finishes, and then if necessary, seconds, thirds, and so on. If a tie still exists after this process a tie shall be declared and awards made accordingly.
- d) In the case of a 2 race format, the points shall be split and for trophy purposes the highest cumulative points for the day will be the trophy winner. Ties shall be broken according to qualifying position. The second race shall be started in order of the first race finishing position.



# JAMAICA MILLENNIUM MOTORING CLUB

## Circuit Racing Technical Regulations

The Circuit Racing Technical Regulations is a part of the JMC Motor Sports Rules and Regulations. The Circuit Racing Technical Regulations shall be used in conjunction with Sections 1 and 2 of the Motor Sport Rules and Regulations and the Circuit Racing General Regulations.

### Table of Contents

Part 22	Mandatory Requirements for all Vehicles
Part 23	Principles of Classification
Part 24	Improved Production
Part 25	Modified Production
Part 26	Grand Touring and Sports Prototypes

### **22**      **Mandatory Requirements for all Vehicles**

- a) The responsibility to ensure that the vehicle and driver's equipment complies with the Regulations and is safe rests solely and at all times with the entrant and driver. The inspection of a vehicle is not a guarantee of the vehicle's safety.
- b) All articles or equipment, which if left loose could present a hazard to the driver, shall be properly secured or removed prior to competition.
- c) All cars must be fitted with a body of adequate strength and construction which will provide a compartment for the driver to be effectively isolated from the engine, gearbox, transmission, drive shafts, battery, fuel, oil, road wheels and suspension. There shall be a protective bulkhead between the engine, gas/oil tank(s), battery, and the driver's/passenger's compartment, suitable and sufficient to prevent the passage of flame in the case of a fire. An exception will be made for vehicles fitted with a properly installed FIA approved fuel cell which contains fire protection inherent in its design. However, they will be subject to the following requirements;
  - i) Vehicles fitted with fuel tanks not supplied as standard equipment by the manufacturer shall be vented to outside of the vehicle. The vent or vent hose shall have a one-way check valve to stop the

flow of fuel to the outside of the fuel tank. If the filler hole is situated inside the car, it must be separated from the cockpit by a liquid-tight protection. FIA approved fuel cells (FT3, FT3.5 & FT5) are strongly recommended for all cars.

- d) To complete the weight of the car by one or several ballast they shall be strong and of unitary blocks, fixed by means of tools with the possibility to fix seals, placed on the floor of the cockpit.
- e) Roll cages (also referred to as Safety Cages) of approved specification, suitably padded to protect the head and limbs of the driver with six (6) anchoring points are required for all cars.
  - i) A roll cage is structural framework made up of a main roll-bar and a front roll-bar (or of two lateral roll-bars), their connecting members, one diagonal member, backstays and mounting points. (For example, see drawings 253-3 and 253-4).

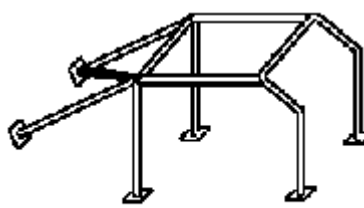

Drawing N° 253-3

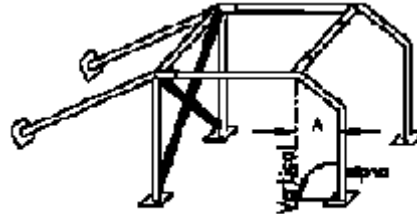

Drawing N° 253-4

- ii) Safety cage must be designed and made so that, when correctly installed, they substantially reduce body-shell deformation and so reduce the risk of injury to occupants.
- iii) The essential features of safety cages are sound construction, designed to suit the particular vehicle, adequate mountings and a close fit to the body-shell.
- iv) Tubes must not carry fluids.
- v) The safety cage must not unduly impede the entry or exit of the driver and co-driver.
- vi) Members may intrude into the occupant's space in passing through the dashboard and front side-trim, as well as through the rear side-trim and rear seats.
- vii) The rear seat may be folded down.
- viii) Longitudinally, the safety cage must be entirely contained between the mounting points of the front and rear suspension elements carrying the vertical loads (springs and shock absorbers).
- ix) Supplementary reinforcements exceeding these limits are authorized between the safety cage and the anchorage points of the rear anti-roll bars on the body-shell.
- x) A diagonal member is compulsory. For examples of different ways of fitting the compulsory diagonal member see drawings 253-3 to 253-5. The combination of several members is permitted according



to drawings 253-3 and 253-5. The fitting of a second diagonal member, according to drawing 253-4, is recommended.

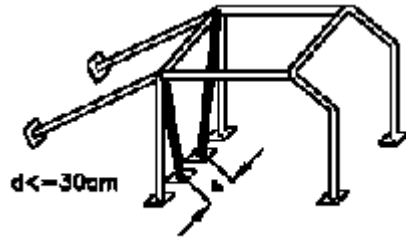

**Drawing N° 253-5**

- xi) One or more door-bars (for side protection) longitudinal members must be fitted at the drivers side of the vehicle (see drawings 253-7, 253-8, 253-12 and 253-17). They may be removable.

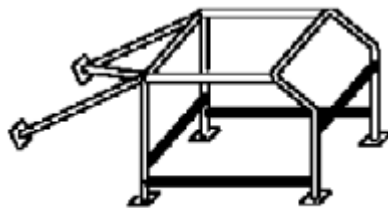

**Dessin / Drawing N° 253-7**

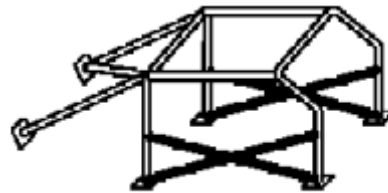

**Dessin / Drawing N° 253-8**

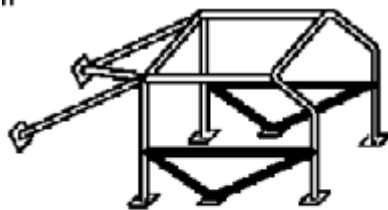

**Dessin / Drawing N° 253-12**

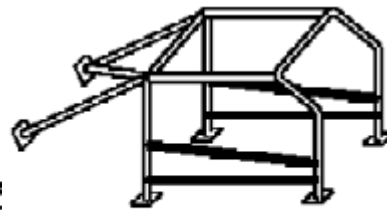

**Dessin / Drawing N° 253-17**

Cette  
l'entre  
This c  
the d

- xii) The side protection must be as high as possible, but its upper attachment point must not be higher than half the height of the door opening measured from its base.
- xiii) If these upper attachment points are located in front of or behind the door opening, this height limitation is also valid for the corresponding intersection of the strut and the door opening.
- xiv) In the case of door-bars in the form of an "X" (cross-struts), it is recommended that the lower attachment points of the cross-struts be fixed directly onto the longitudinal member and that at least one part of the "X" be a single-piece bar.
- xv) Main, front and lateral roll-bars must be made in one piece without joints.
- xvi) Their construction must be smooth and even, without ripples or cracks.
- xvii) The vertical part of the main roll-bar must be as straight as possible and as close as possible to the interior contour of the body-shell.

- xviii) The front leg of a front roll-bar or of a lateral roll-bar must be straight, or if it is not possible, must follow the windscreen pillars and have only one bend with its lower vertical part.
- xix) Where a main roll-bar forms the rear legs of a lateral roll-bar (drawing 253-4), the connection to the lateral roll-bar must be at roof level.
- xx) To achieve an efficient mounting to the body-shell, the original interior trim may be modified around the safety cages and their mountings by cutting it away or by distorting it. However, this modification does not permit the removal of complete parts of upholstery or trim. Where necessary, the fuse box may be moved to enable a roll-cage to be fitted.
- xxi) Mounting of roll-cages to the body-shell: Minimum mountings are:
  - 1 for each leg of the main or lateral roll-bar.
  - 1 for each of the front roll-bar.
  - 1 for each backstay (see xxiii below).
- xxii) Each mounting foot of the front, main and lateral roll-bars must include a reinforcement plate, of a thickness of at least 3 mm (0.118") which must not be less than that of the tube onto which it is welded. Each mounting foot must be attached by at least three bolts on a steel reinforcement plate at least 3 mm (0.118") thick and of at least 120 cm<sup>2</sup> (7.322 inch<sup>2</sup>) area which is welded to the body-shell. Examples are shown in Drawings 253-18 to 253-24 (for drawings 253-18 and 253-20, the reinforcement plate does not necessarily have to be welded to the body-shell).

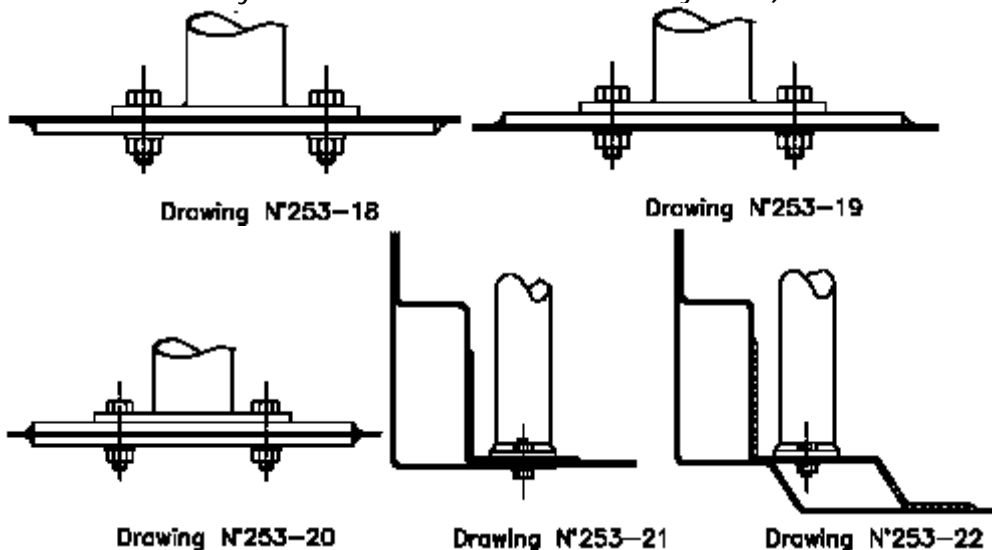

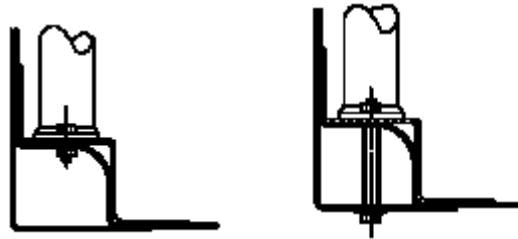

**Drawing N°253-23      Drawing N°253-24**

This does not necessarily apply to backstays (see item xxiii below). Bolts must be of at least M8 size of ISO standard 8.8 or better. Fasteners must be self-locking or fitted with lock washers.

These are minimum requirements. In addition to these requirements, more fasteners may be used, the roll-bar legs may be welded to reinforcement plates, and the roll-cage may be welded to the body-shell. Roll-bar mounting feet must not be welded directly to the body-shell without a reinforcement plate.

- xxiii) Backstays: These are compulsory and must be attached near the roofline and near the top outer bends of the main roll-bar on both sides of the car. They must make an angle of at least 30° with the vertical, must run rearwards and be straight and as close as possible to the interior side panels of the body-shell. Their materials specification, diameter and thickness must be as defined below. Their mountings must be reinforced by plates. Each backstay should be secured by bolts having a cumulative section area at least two thirds of that recommended for each roll-bar leg mounting, and with identical reinforcement plates of at least 60 cm<sup>2</sup> (9.30 inch<sup>2</sup>) area (see drawing 253-25). A single bolt in double shear is permitted, provided it is of adequate section and strength (see drawing 253-26) and provided that a bush is welded into the backstay.



**Drawing N°253-25      Drawing N°253-26**

- xxiv) Diagonal members: At least one diagonal member must be fitted. Their location must be in accordance with drawings 253-3 to 253-5 and they must be straight, not curved. The attachment points of the diagonal members must be so located that they cannot cause injuries. They may be made removable but must be in place during events. The lower end of the diagonal must join the main roll-bar of backstay not further than 100 mm (3.93") from the mounting foot. The upper end must join the main roll-bar not further than 100 mm (3.93") from the junction of the backstay joint, or the backstay not more than 100 mm (3.93")

from its junction with the main roll-bar. They must comply with the minimum specification set out in Article 22 e xxvi. Diagonal members fixed to the body- shell must have reinforcement plates as defined in Article 22 e xxvi.

- xxv) Optional reinforcement of the roll-cage: The diameter, thickness and material of reinforcements must be as defined in Article 22 e xxvi. They shall be either welded in position or installed by means of dismountable joints.
- xxvi) Specifications of the tubes used:
  - a) Main roll bar, Lateral roll bar and their connections: Cold drawn seamless unalloyed carbon steel 40mm x 2.0mm (1.75" x 0.098") minimum.
  - b) Other parts of safety cage: Cold drawn seamless unalloyed carbon steel 38mm x 2.5mm (1.5" x 0.098") or 40mm x 2mm (1.6" x 0.078").
- f) Safety Belts are mandatory for all cars. A safety harness must be used in its homologation configuration without any modifications or removal of parts, and in conformity with the manufacturer's instructions. The required minimum is a five (5) point harness with 3 inch lap for all occupants. The recommended geometrical locations of the anchorage points are shown in drawing N° 253-42.

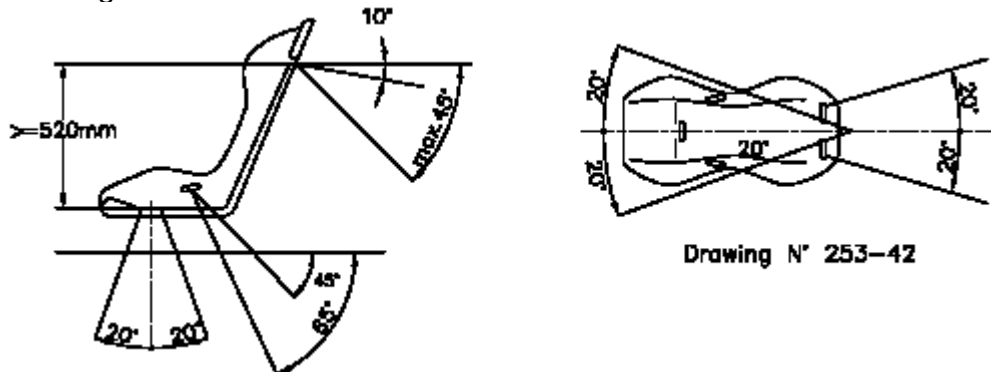

Drawing N° 253-42

In the downwards direction, the shoulder straps must be directed towards the rear and must be installed in such a way that they do not make an angle of more than 45° to the horizontal from the upper rim of the backrest, although it is recommended that this angle should not exceed 10°.

The maximum angles in relation to the centre-line of the seat are 20° divergent or convergent.

Anchorage points creating a higher angle to the horizontal must not be used unless the seat meets the requirements of the FIA standard.

In that case, the shoulder straps of 5-point safety harnesses may be installed on the rear seat lap strap anchorage points originally mounted by the car manufacturer.

A safety harness must not be installed on a seat having no head restraint or having a backrest with integrated head restraint (no opening between backrest and head restraint).

The lap and crotch straps should pass not over the sides of the seat but through the seat, in order to wrap and hold the pelvic region over the greatest possible surface.

The lap straps must fit tightly in the bend between the pelvic crest and the upper thigh. Under no conditions must they be worn over the region of the abdomen.

Holes may be made in the series seat. Care must be taken that the straps cannot be damaged through chafing against sharp edges.

The shoulder straps may also be fixed to the safety roll cage or to a reinforcement bar by means of a loop, and may also be fixed to the top anchorage points of the rear belts, or be fixed or leaning on a transversal reinforcement welded to the backstays of the roll-bar.

- g) Driver's seat shall be securely fixed and shall be of sound construction.
- h) All vehicles excluding single-seater type cars shall have a driver's window net, which shall comply with the following;
  - 1) Be of the ribbon type and cover 70% of the driver's window area.
  - 2) The net shall be permanently attached to the lower edge of the window.
  - 3) The upper attachment shall be of a quick release type.
- i) At least one (1) fire extinguisher is mandatory. ~~of the~~ Dry chemical type must have a minimum capacity of at least 1 kg. Halon type at least 18 oz.
- j) All exhaust shall vent to the outside and away from the body of the car. Exhaust noise shall not exceed 103 db at 10ft measured at a 45 degree angle to the actual point of exit. This shall be measured at 1400 rpm for Improved Production (IP) and at 6500 rpm for Modified Production (MP) and GTS classes.
- k) The battery shall be securely mounted and insulated.
- l) All vehicles with open type sump breather shall vent into a catch tank with a minimum capacity equivalent to 60% of the engine cc rating. The catch tank shall either be translucent or have a translucent type window.
- m) All vehicles shall be fitted with mirrors that provide driver visibility to the rear of both sides of the vehicle.
- n) All vehicles shall be fitted with a front and a rear towing eye. The towing eye shall be clearly visible and painted, or the location indicated in, yellow, red or orange.
- o) All vehicles with the exception of formula cars shall be fitted with two operating red brake lights. Formula cars shall have a red light on the rear clearly visible and shall be illuminated in instances of rain.
- p) Brakes shall be pedal operated working directly on each wheel and in perfect working order.

- q) Suspension and steering shall be of suitable design and be of proper working order. Spherical rod ends shall be retained either by the design of the mounting bracket or by a captive washer.
- r) Hoods shall have two independent fasteners of adequate strength, which simultaneously secure the panel closed.
- s) All vehicles shall have a master circuit breaker, which will cut all electrical power and shall be mounted, in a position easily accessible from outside the vehicle. It shall be clearly marked by the official international marking, a red spark in a white edged blue triangle.
- t) All vehicles shall have an onboard starter, which must be able to start the vehicle at the beginning of the race.
- u) Driver's equipment (garments and helmets) shall comply with the FIA regulations for circuit racing. These are as follows:  
Helmets: FIA 8860-2004, SNELL SA2000, SFI 31.1A or 31.2A, BS6658-type AF/R.  
Clothing: Overalls as well as gloves, long underwear, a balaclava, socks and shoes homologated to the FIA 8856-2000 or FIA 1986\* standard.  
*\* End of validity of the FIA 1986 standard for overalls, long underwear, balaclavas, socks and shoes : 31.12.2004. End of validity of the FIA 1986 standard for gloves : 31.12.2005.*
- v) The use of Nitrous Oxide (N<sub>2</sub>O) is forbidden in all groups and classes. Only air may be mixed with the fuel as an oxidant. Racing gasoline, gasoline, methanol, gasohol, diesel, ethanol, natural gas and propane are permitted. Nitromethane is prohibited.
- w) Nut, bolts, fasteners, fuses, circuit breakers, gaskets, hoses, bearings, seals, return springs and fittings are free.
- x) Lubricants and Fluids are free unless stated otherwise in class regulations or ASR's.
- y) Identification marks: Each vehicle shall carry identification numbers, class letters, or other marks required by the ASR's. Numbers shall be placed on the front and both sides of the vehicle in a legible position. All vehicles shall carry numbers at least eight inches high with a one and a half to two inch stroke (8" H x 1 1/2"-2" Stroke). All numbers shall have a sharply contrasting background and the distance between two numbers shall be at least as wide as the stroke of the numbers.

## **23 Principles of Classification**

If these Regulations do not specifically state modifications may be made or specific variations to OEM specifications are permitted, then no additional modifications or variations are permitted. This will be a major factor in the settling of any disputes arising from questions of eligibility. If a car is found not to comply with the technical regulations, it shall be no defense to claim that no performance advantage was obtained.

- a) Cars shall be divided into three (3) groups:  
Improved Production (IP 0, 1, 2 & 3 & 4)  
Modified Production (MP 0, 1, 2 & 3 & 4)  
Grand Touring & Sports Prototypes (GTS)
- b) In case of forced induction, the nominal cylinder-capacity will be multiplied by 1.7 for petrol engines, by 1.5 for diesel engines and by 1.35 for rotary engines, and the car will pass into the class corresponding to the fictive volume thus obtained.
- c) In order to determine the classification of a car using an engine of the NSU Wankel patents (Rotary Engines), the manufacturers claimed cylinder displacement should be increased by a factor of 2. If the same engine also employs a system of forced induction, then the 1.35 factor shall also apply. For example a Mazda 13B engine rated at 1308 cc would be classified as 2,616 cc (1308 x 2). If the same engine was turbo charged then the displacement would be 3,531.6 cc (1308 x 2 x 1.35).
- d) Improved & Modified Production classes are for vehicles which are generally available for sale to the general public for normal road use. Improved & Modified Production, classes 0, 1, & 2 & 3 must qualify as a legal five passenger vehicle minimum in their OEM specification. Vehicles that meet the requirements of IP and MP with the exception of the minimum passenger requirements shall be classified in class 3 & 4 of the respective group.
- e) The following chart will establish wheel widths and weights for the classes listed.

<b>Engine Capacity</b>	<b>Max. Wheel Width</b>	<b>lbs/cc</b>
<b>i) Improved Production (IP 0, 1, 2, 3)</b>		
Up to 1400cc	8.0	1.125
1401-1800cc	8.0	1.125
1801-3000cc	9.0	0.89
Over 3000cc & Sports cars	10.0	0.80

For IP 3 & IP4, turbocharged two-wheel-drive (2WD) cars may subtract 100lbs from their calculated weight. i.e. a turbocharged 2000cc 2WD may weigh 2620lbs ((2000 x 1.7 x .80) – 100).

<b>ii) Modified Production (MP 1, 2, 3)</b>		
Up to 1800cc	11.0	0.81
1801cc to 3000cc	11.0	0.81
over 3000cc & sports cars	13.0	0.70

For MP4, turbocharged two-wheel-drive (2WD) cars may subtract 100lbs from their calculated weight. i.e. a turbocharged 2000cc 2WD may weigh 2280lbs ((2000 x 1.7 x .70) – 100).

**iii) Grand Touring & Sports Prototypes (GTS)**

Unlimited

14.0"

0.65

- f) The onus is on the competitor to have the vehicle at the legal weight at all times during an event. The legal weight shall be in accordance with the technical regulations for the car as qualified or raced with the driver on board. When called upon to have a vehicle weighed, the following shall apply:
- 1) Cars shall be weighed under the supervision of the Technical Inspector or his designate on the official scale for the event.
  - 2) The car shall be presented with its gas tank(s) as close to empty as possible.
  - 3) All articles which are not an integral part of the vehicle and its equipment shall be removed.
  - 4) To complete the weight of the car by ballast, they shall be strong and of unitary blocks, fixed by means of tools with the possibility to fix seals, placed on the floor of the cockpit.
  - 5) For the purpose of arriving at 'weight' the weight ratios in the technical regulations shall include an additional 120 pounds. (Thus the weight for an IP1 car shall be the cc X 1.125 + 120 lbs. with the driver on- board).

**24 Improved Production**

- a) The Spirit of the Rule
- i) The purpose of the Improved Production ~~and~~ category shall be to provide a category of racing cars for competitors who desire to compete in series-produced automobiles generally available for purchase by the public, and who additionally desire to improve the performance of these cars within specific and uniform preparation limitations. The Improved Production category is intended for cars which are street legal with the exception of exhaust noise. The spirit of the rule shall be respected.
- b) Bodywork, *Exterior*
- i) Spoilers, doors, hoods, trunk lid and bumpers may be of alternate material as long as the profile remains the same as the OEM parts. The exterior contour of the fenders may be altered to provide tyre clearance provided that the fender opening profile viewed from the side of the automobile is not dramatically changed. Fender flares may be of alternate material. Air ducting is for the passage of air



- only and shall not alter the profile of the bodywork. All windows and glasses with the exception of the front windshield may be replaced with Perspex, Lexan or similar transparent material.
- ii) Strengthening of the sprung parts of the chassis and bodywork is allowed provided that the material used follows the original shape and is in contact with it. Insulating and sound proofing materials may be removed. Unused supports (e.g. spare wheel) situated on the chassis/bodywork can be removed, unless they are supports for mechanical parts that cannot be moved or removed. It is possible to close the holes in the cockpit, the engine and luggage compartments, and in the fenders. The holes may be closed using sheet metal or plastic materials, and may be welded, stuck or riveted. The other holes in the bodywork may be closed by adhesive tape only.
  - iii) Vehicles must be equipped with functional OEM headlights, brake lights, signal lights, reverse light, and windscreen wipers.
  - iv) Protective headlight covers may be fitted provided that their only function is to cover the glass, and that they have no influence on the car's aerodynamics.
  - v) The fitting of underbody protections is authorized, which are removable and which are designed exclusively and specifically in order to protect the following parts: engine, radiator, suspension, gearbox, tank, transmission, and exhaust.
  - vi) The fitting of additional external rear view mirrors is authorized.
- c) *Bodywork, Passenger Space*
- i) All accessories which have no effect on the vehicle's behavior are allowed without restrictions, such as those concerning the aesthetics or interior comfort (lighting, A/C, radio, etc.) on the express condition that they do not influence, even in a secondary manner, the efficiency of the engine, steering, strength, transmission, braking, or road-holding.
  - ii) The OEM dashboard shall remain in its original location and may only be modified to accommodate the roll cage or to mount instruments, gauges or switches etc. Carpets and rear seats may be removed and the front seats may be replaced with competition items.
  - iii) Additional measuring instruments, counters, etc. may be freely installed, provided that their fitting is not likely to create any danger.
  - iv) The steering wheel is free. The locking system of the anti-theft steering lock may be rendered inoperative.
- d) *Engine*
- Engine shall be one of the versions offered by the manufacturer of the car (i.e.: Ford engine in a Ford car). Modifications are free with the following restrictions:

- i) Ignition system is free.
- ii) Cooling system is free.
- iii) The fitting of baffles in the oil sump is authorized. Dry Sump lubrication systems are not allowed.
- iv) Oil cooler(s) may be added provided that they are mounted within the perimeter of the bodywork and are not visible from above.
- v) Engine mountings are free, but not the number or location of engine mountings.
- vi) Re-boring of the cylinder is allowed as per the OEM service manual.
- vii) Vehicles competing in Improved Production Class 3, employing a system of forced induction will be required to fit a 34mm restrictor as per the following regulations:

The maximum internal diameter of the restrictor is 34mm, maintained for a minimum distance of 3 mm measured downstream of a plane perpendicular to the rotational axis situated at a maximum of 50 mm upstream of a plane passing through the most upstream extremities of the whole blades (see drawing 254-4).

This diameter must be complied with, regardless of the temperature conditions.

The external diameter of the restrictor at its narrowest point must be less than 40 mm, and must be maintained over a distance of 5 mm to each side.

The mounting of the restrictor onto the turbocharger must be carried out in such a way that two (2) screws have to be entirely removed from the body of the compressor, or from the restrictor, in order to detach the restrictor from the compressor. Attachment by means of a needle screw is not authorized.

For the installation of this restrictor, it is permitted to remove material from the compressor housing, and to add it, for the sole purpose of attaching the restrictor into the compressor housing. The heads of the screws must be pierced so that they can be sealed.

The restrictor must be made from a single material and may be pierced solely for the purpose of mounting and sealing, which must be carried out between the mounting screws, between the restrictor (or the restrictor/compressor housing attachment), the compressor housing (or the housing/flange attachment) and the turbine housing (or the housing/flange attachment) (see drawing 254-4).

In case of an engine with two parallel compressors, each compressor must be limited by a restrictor with a maximum internal diameter of 24.0 mm and a maximum external diameter of 30 mm, in the conditions set out above.

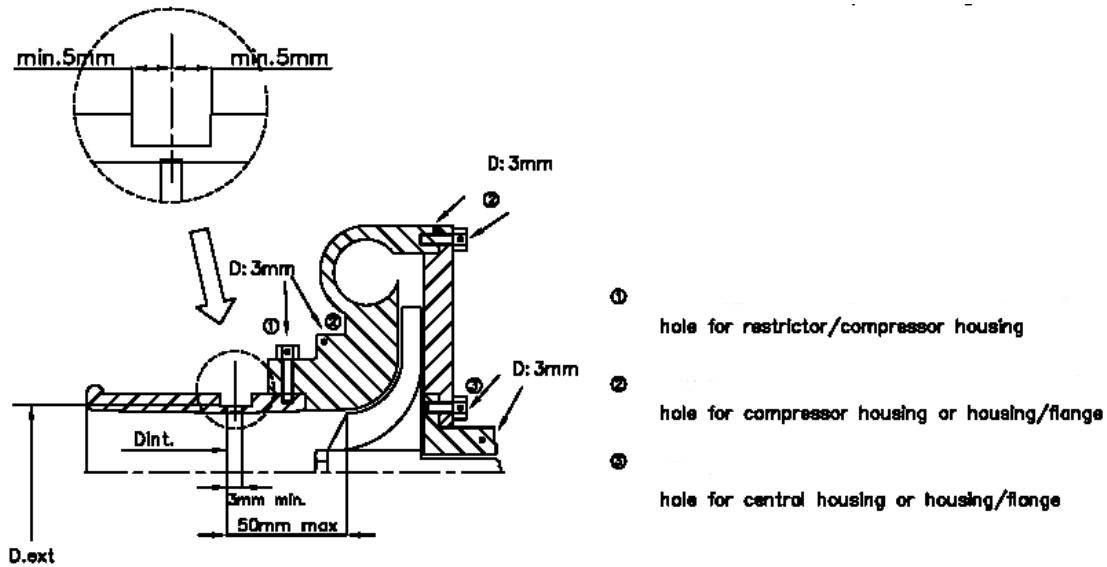

Drawing N°254-4

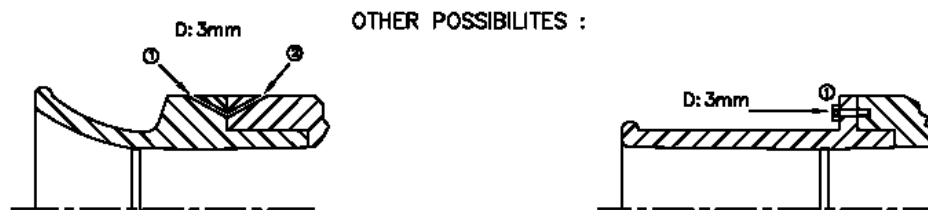

e) Fuel System

- i) Fuel system is free providing that:
  - 1) FIA Approved Fuel Cell (FT3, FT3.5 & FT5) is optional.
  - 2) The fuel filler holes may not be located in the window panels.
- ii) Fuel lines must be changed for aviation type lines if an FT3, FT3.5 or FT5 tank is used, the route of these lines being free. Should an OEM tank be used, this change is optional.
- f) The exhaust system is free, but must extend to the rear of the car and exit in the approximate location of the original system. For cars with a turbo charger, the exhaust manifold system begins after the turbo charger.
- g) Brake and Clutch:
  - i) The Brake and Clutch are free, but the use of carbon brake discs is prohibited.
  - ii) Protection shields may be modified or removed, but material may not be added.
  - iii) Only one flexible pipe to bring the air to the brakes of each wheel is allowed, but it's inside section must be able to fit into a circle with a 10cm diameter. The air pipes must not go beyond the perimeter of the car, seen from above.

- iv) The handbrake shall function in its normal manner but the mechanism of the handbrake lever may be adapted in order to obtain instant unlocking (fly-off handbrake). The mechanical handbrake may be replaced with a hydraulic system.
- h) Drive Train
  - i) Alternative gear & final drive ratios may be used and the differential action may be altered by either a Limited Slip device or other means as long as the transmission and/or differential housing are from the manufacturer of the vehicle.
  - ii) Axles and CV joints are free.
  - iii) Traction Control systems are not permitted.
- i) Suspension
  - i) Bushings and mounts are free but not the number or location.
  - ii) Suspension anchorage points may be reinforced only by the addition of material.
  - iii) The body shell may be seam welded and transverse strut braces may be fitted. Springs and dampers are free provided that the locating points are not moved from the original position.
  - iv) Suspension arms and links are free but not the principle of operation.
  - v) Anti-roll bars may be added or removed, however the addition must serve only one function.
- j) Wheels and Tyres
  - i) The complete wheel shall be enclosed within the bodywork when the wheel is in a straight-ahead position and viewed from above.
  - ii) Rim width and diameter may be varied by two (2") inches from the OEM specification.
  - iii) Tyres shall be DOT or ECE street legal. (no racing slicks).
  - iv) Alloy wheels are permitted.
  - v) Hubcaps shall be removed.
- k) Electrical System
  - i) The make and capacity, of the battery cables are free. The battery shall be securely mounted and insulated.
  - ii) Alternators and generators are free but shall function in their normal manner.
  - iii) Additional headlights including the corresponding relays are allowed, provided that the total does not exceed eight.
  - iv) An additional reversing light may be fitted provided it can only be used when the gear lever is in the "reverse" position, and provided that the police regulations on this subject are observed.
  - v) The horn may be changed but shall function in the normal manner.
  - vi) All vehicles shall have an onboard starter, which must be able to start the vehicle at the beginning of the race.

## **25 Modified Production**

- a) Engine and transmission/gearbox shall not be moved more than six (6) inches from the original location.
- b) The overall structure of the car around which are assembled the mechanical components and the bodywork including any structural part of the said structure (i.e. the chassis) may be modified or constructed with tubular steel.
- c) The exhaust system is free.
- d) The Brake and Clutch are free, but the use of carbon brake discs is prohibited.
- e) Traction Control systems are not permitted.
- f) Active suspension systems are not permitted.
- g) Ignition system is free.
- h) Cooling system is free.
- i) Engines are free. (i.e. Nissan engine in a Mazda car). Modifications are free.
- j) Oil cooler(s) shall be mounted within the perimeter of the bodywork and are not visible from above.
- k) Fuel system is free providing that fuel lines shall be of the aviation type lines if the fuel tank is not OEM.
- l) Lubricants and Fluids are free.
- m) Bodywork, Exterior, is free with the following restrictions:
  - i) The profile of the vehicle when viewed from the side of the automobile is not dramatically changed with the exception of the front and rear air spoilers. All windows and glasses may be replaced with Perspex, Lexan or similar transparent material.
- n) Spoilers and air dams and side skirts are free.
- o) Air ducting is free for the passage of air only and shall not alter the profile of the bodywork when viewed from above.
- p) No part of the car must touch the ground when all the tyres on one side are deflated. This test shall be carried out on a flat surface under race conditions (driver on board).
- q) Electrical System
  - i) The make and capacity of the battery cables are free. The battery shall be securely mounted and insulated.
  - ii) All vehicles shall have an onboard starter, which must be able to start the vehicle at the beginning of the race.
- r) Wheels and Tyres are as per the chart of wheel / weight specifications for Modified Production however racing slicks and alloy wheels are permitted.

## **26 Grand Touring and Sports Prototypes (GTS)**

- a) Engine, Ignition, Fuel, Cooling, and Lubrication: are free, however all radiators and oil cooler(s) shall be mounted within the perimeter of the bodywork and are not visible from above.
- b) The bodywork shall enclose the complete road wheel when viewed from above.
- c) No active suspension or traction control systems allowed.
- d) No carbon brake discs are allowed.
- e) The make and capacity of the battery cables are free.
- f) The battery shall be securely mounted and insulated.
- g) All vehicles shall have an onboard starter which must be able to start the vehicle at the beginning of the race.
- h) Wheels and Tyres are as per the chart of wheel / weight specifications for GTS class; however racing slicks and alloy wheels are permitted.

7.5"	142 x 140	19880	1988
7"	133 x 140	18620	1862
6.5"	124 x 140	17360	1736

Length and Width dimensions are in millimeters (mm).  
Surface and 10% rate dimensions are in mm<sup>2</sup>.

The tread pattern must be molded.

Tyre cutting is authorized.

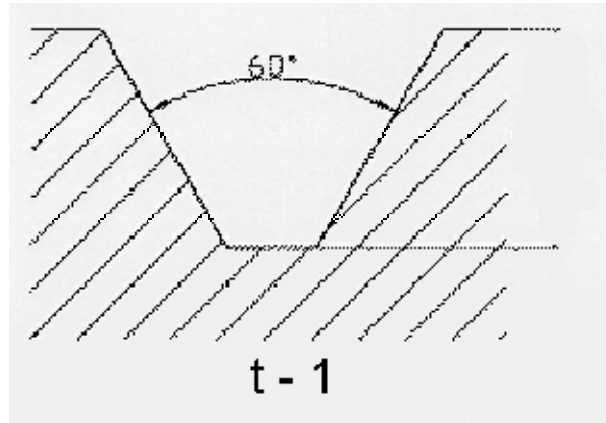

By authority of  
Competition Sub-Committee  
Jamaica Millennium Motoring Club